

QK.41 - łóżko TURBO PRAWIE

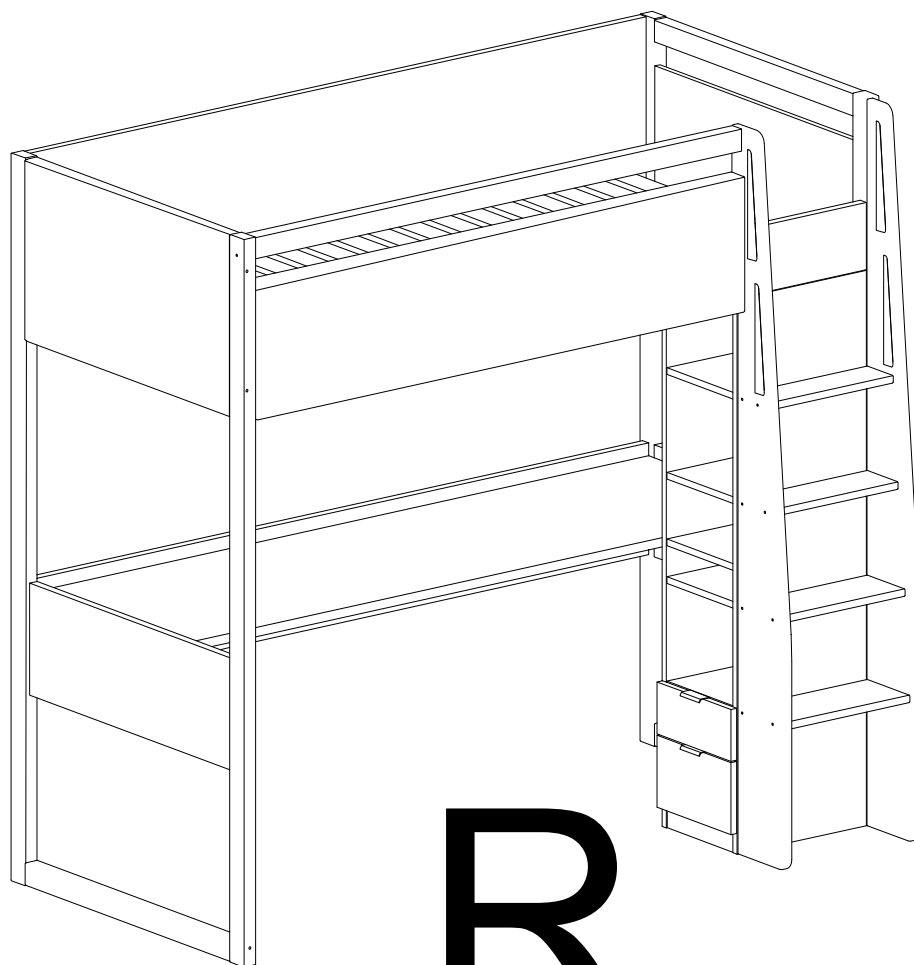

R

X

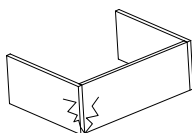



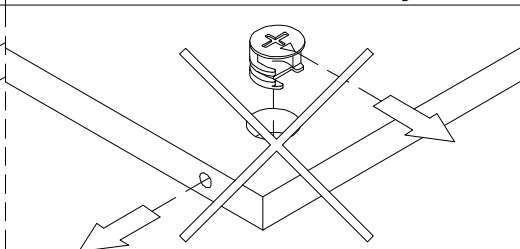
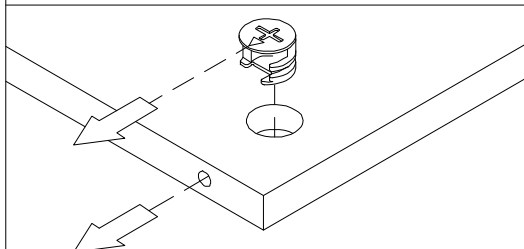
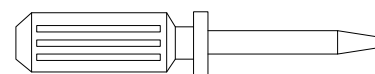
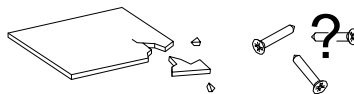
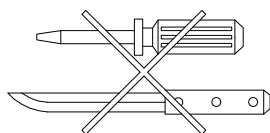
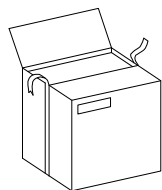
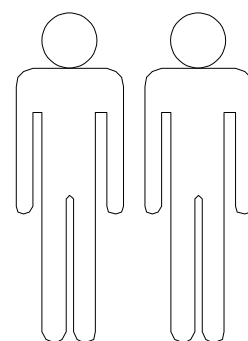
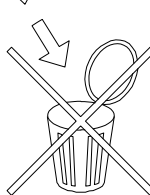
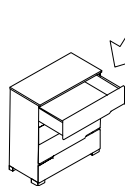
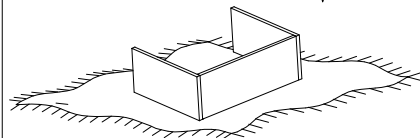

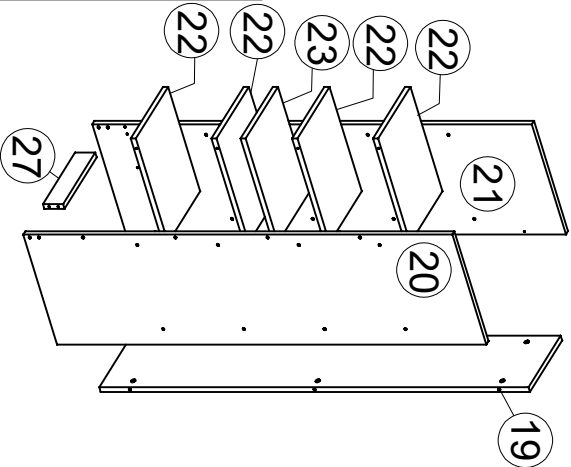
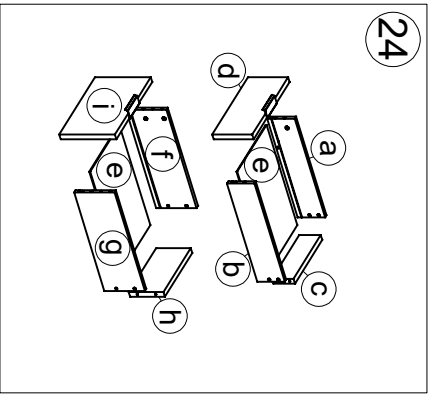
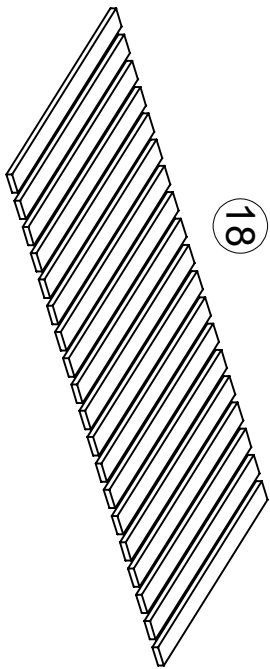
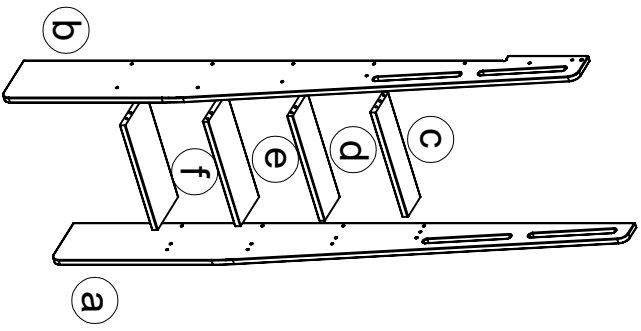
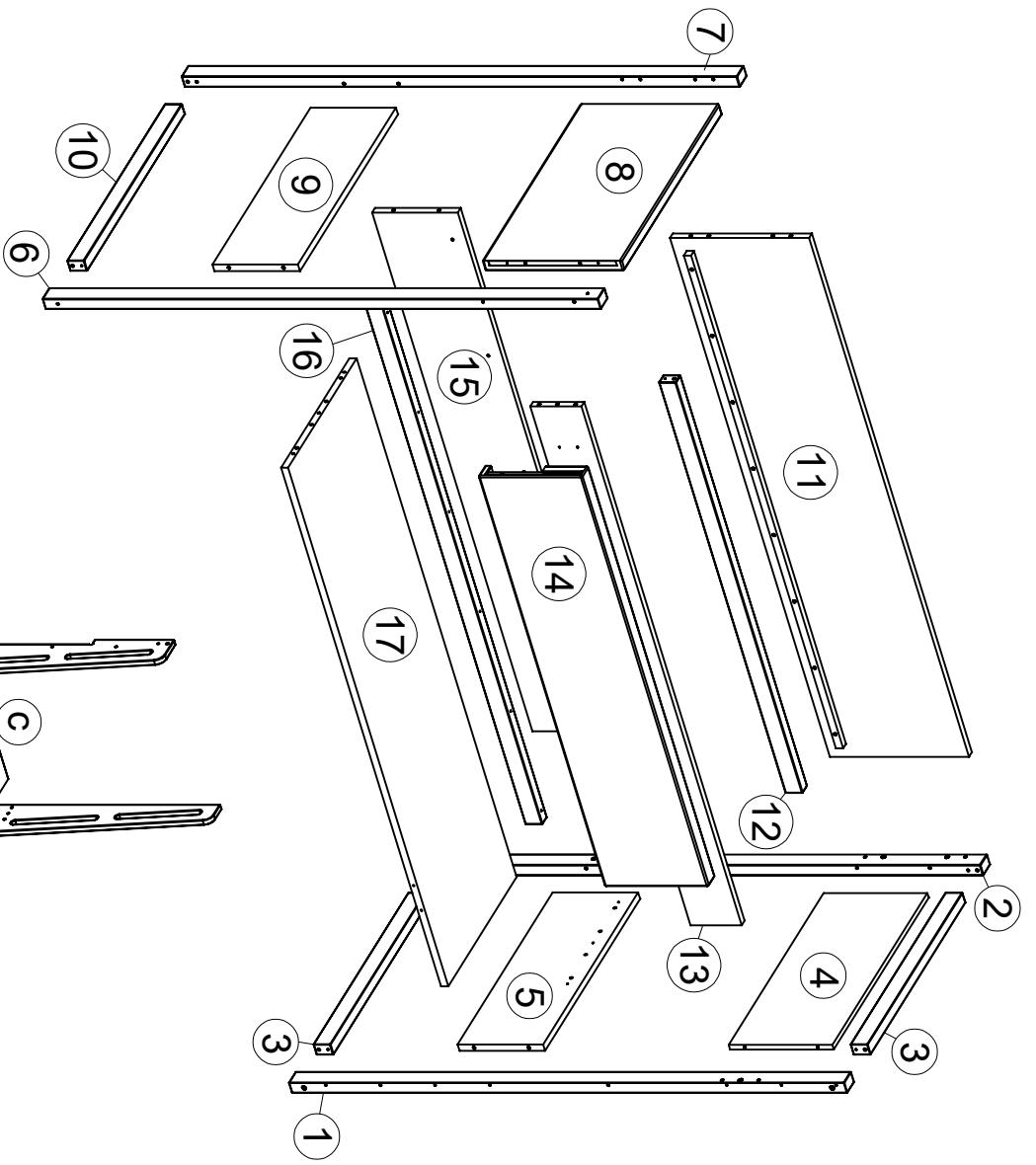



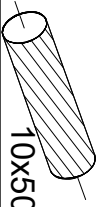
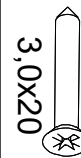
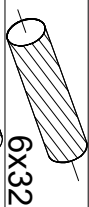
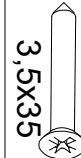

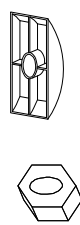

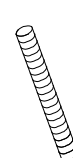
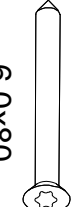
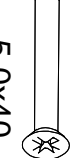

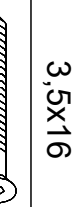
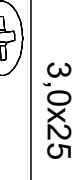
✓

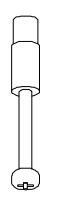
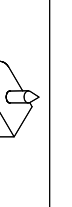

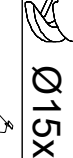

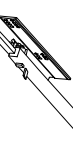
ŁÓŻKO TURBO

	Id	pcs.		Id	pcs.
W106	 10x50	32	W63	 3,0x20	2
W61	 6x32	6	W122	 3,5x35	6
W4	 8x36	27	W164		10
W231	 6,3x90	11		 5,0x40	6
	 6,0x80	12	W62	 3,0x25	4
W10	 3,5x16	4	W11		4
W14	 7,0x50	58	W50	 Ø12x9,5	6
W2	 Ø15x23	18	W78	 Ø15x18	6
W8	 Ø15x18	4	W1		6
W13	 6,3x13	12	W27	 2L,2R	
W20	 2	2	W211	 2	
W165	 T30x70	1		 S = 4	1
	 Ø15	5			1
	 40				

Nr	A x B x C [mm]	PCS.
1	1950x60x40	1
2	1950x60x40	1
6	1950x60x40	1
7	1950x60x40	1
12	1583x60x40	1
10	860x60x40	1
3	834x60x40	2
c	398x110x20	1
d	398x130x20	1
e	398x160x20	1
f	398x180x20	1
16	2000x60x40	1

Nr	A x B x C [mm]	PCS.
4	834x364x18	1
23	279x397x18	1
22	279x397x18	4
27	279x70x18	1
24d	311x139x18	1
24i	311x193x18	1
6/8 24 a,b	375x95x12	2
24 g,f	375x140x12	2
24c	237x75x18	1
24h	237x120x18	1
24e	382x249x3	2
-	OKUCIA / FITTINGS / ΦΥΡΗΝΤΥΡΑ / FERONERIE / BESCHLÄGE / KIINNITTIMET	1

Nr	A x B x C [mm]	PCS.
2/8 a	1948x202x19	1
b	1950x229x19	1

Nr	A x B x C [mm]	PCS.
7/8 14	1583x364x58	1
8	860x488x38	1

Nr	A x B x C [mm]	PCS.
3/8 17	2000x600x25	1

Nr	A x B x C [mm]	PCS.
8/8 18	900x2000x60	1

Nr	A x B x C [mm]	PCS.
9	860x300x25	1
5	834x300x25	1
20	1488x419x18	1
21	1525x419x18	1
19	1488x279x18	1

Nr	A x B x C [mm]	PCS.
15	2000x300x25	1
11	2000x488x25	1
13	2000x180x25	1

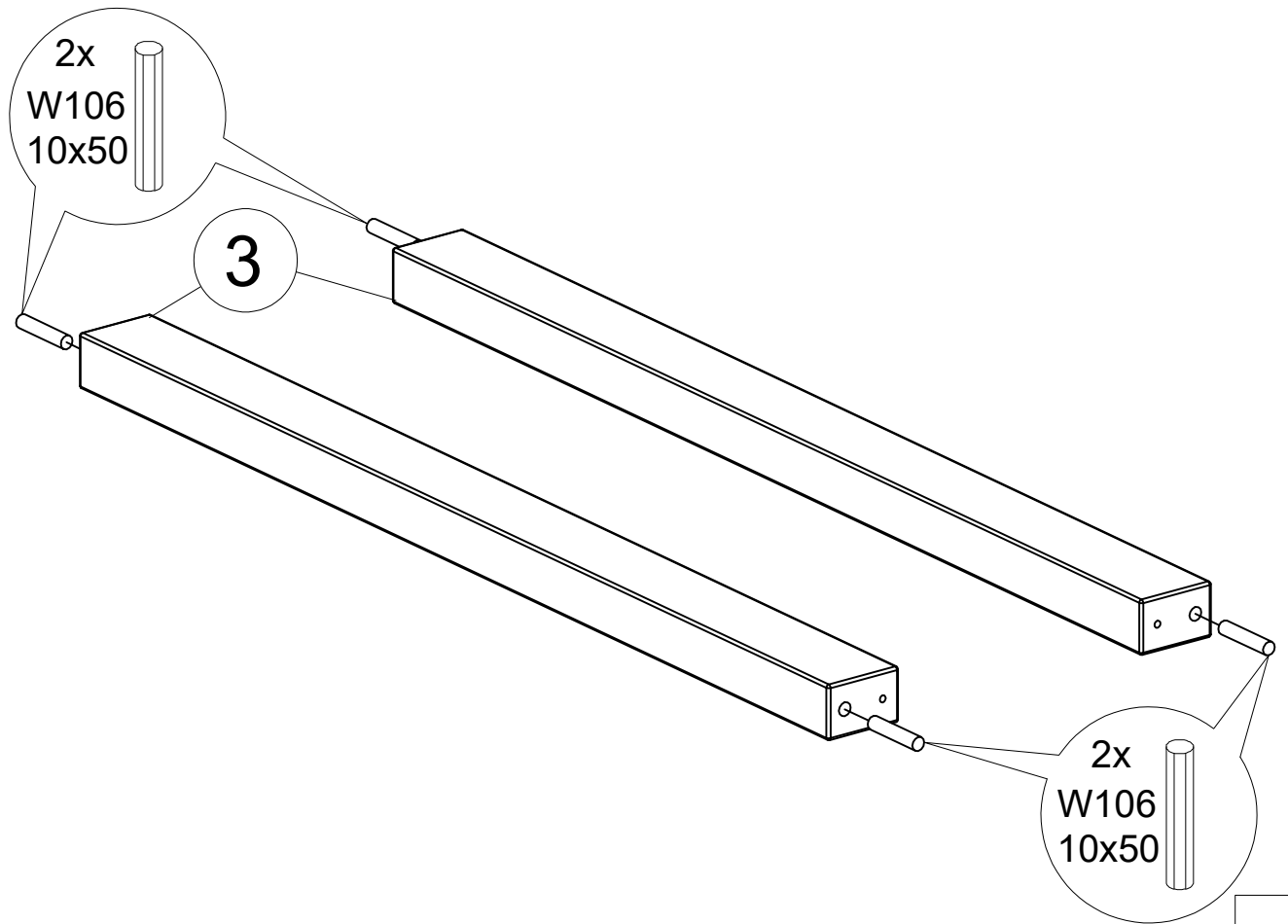

1

2

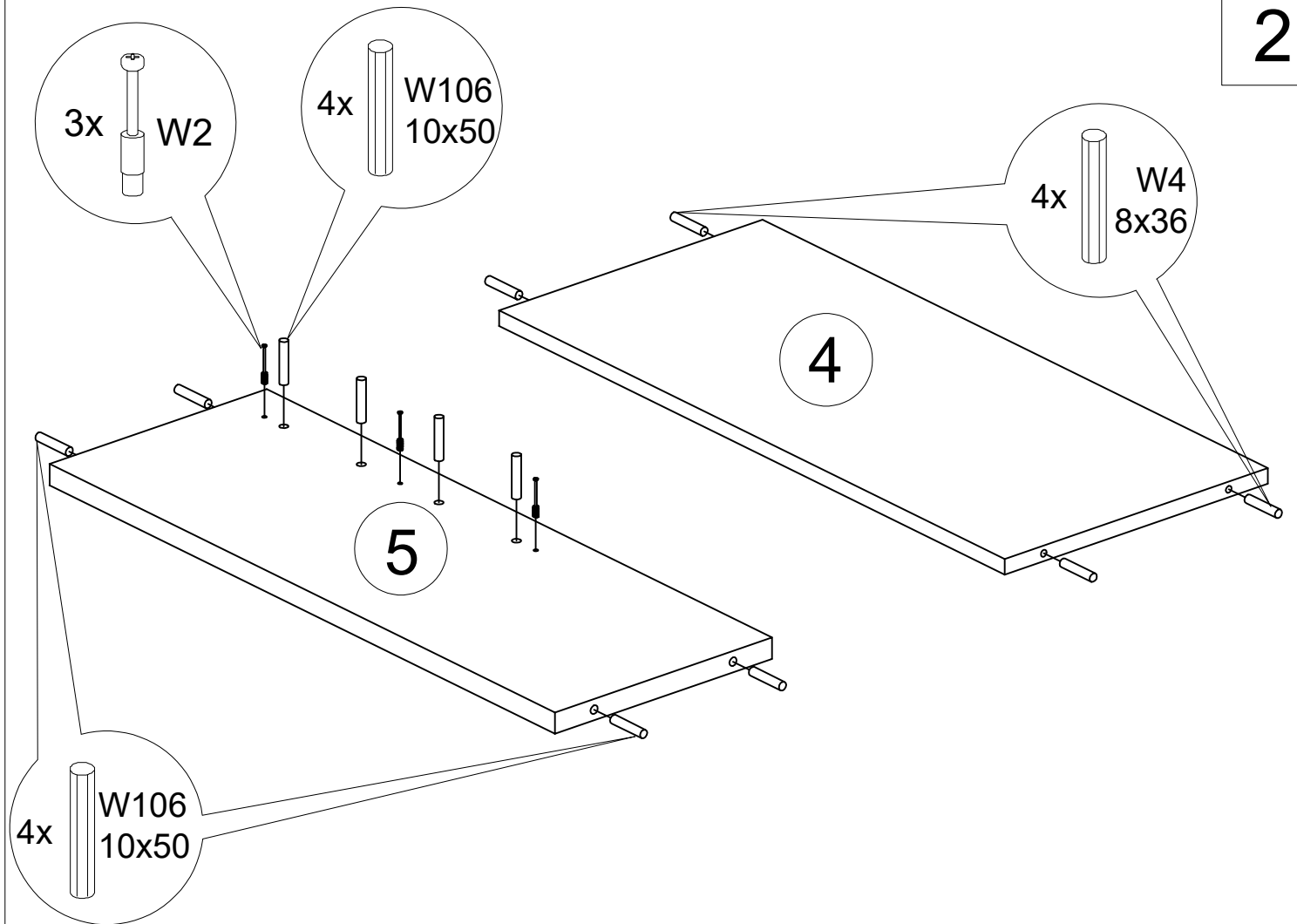

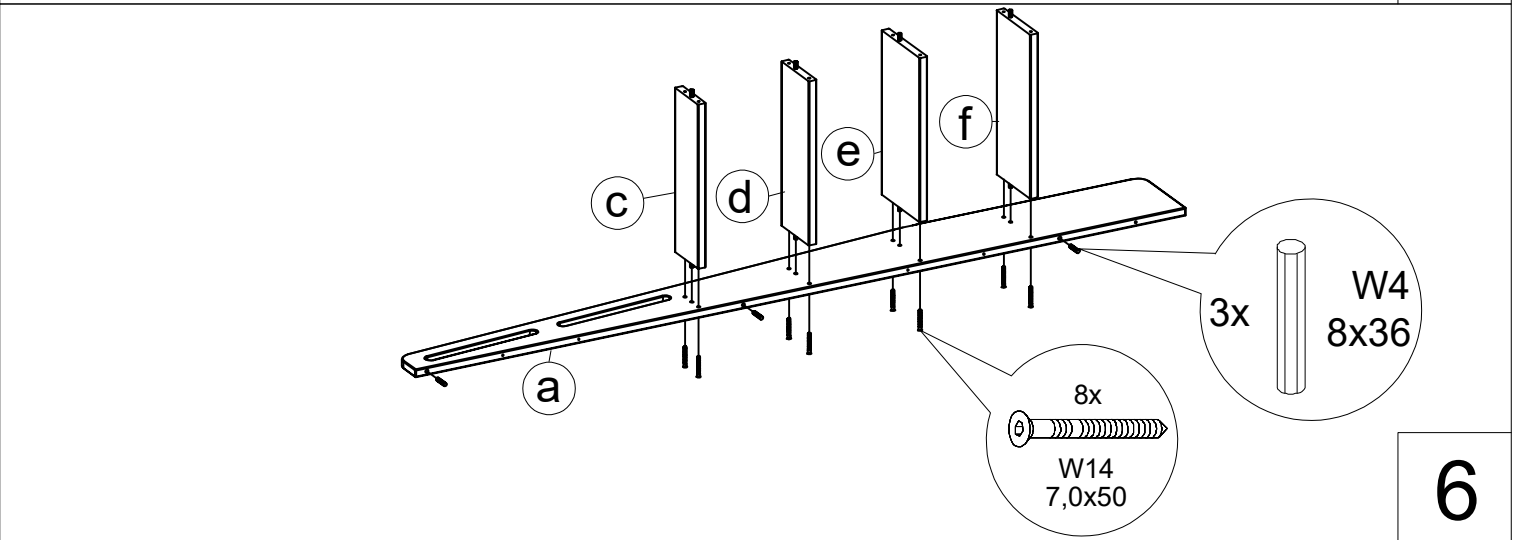
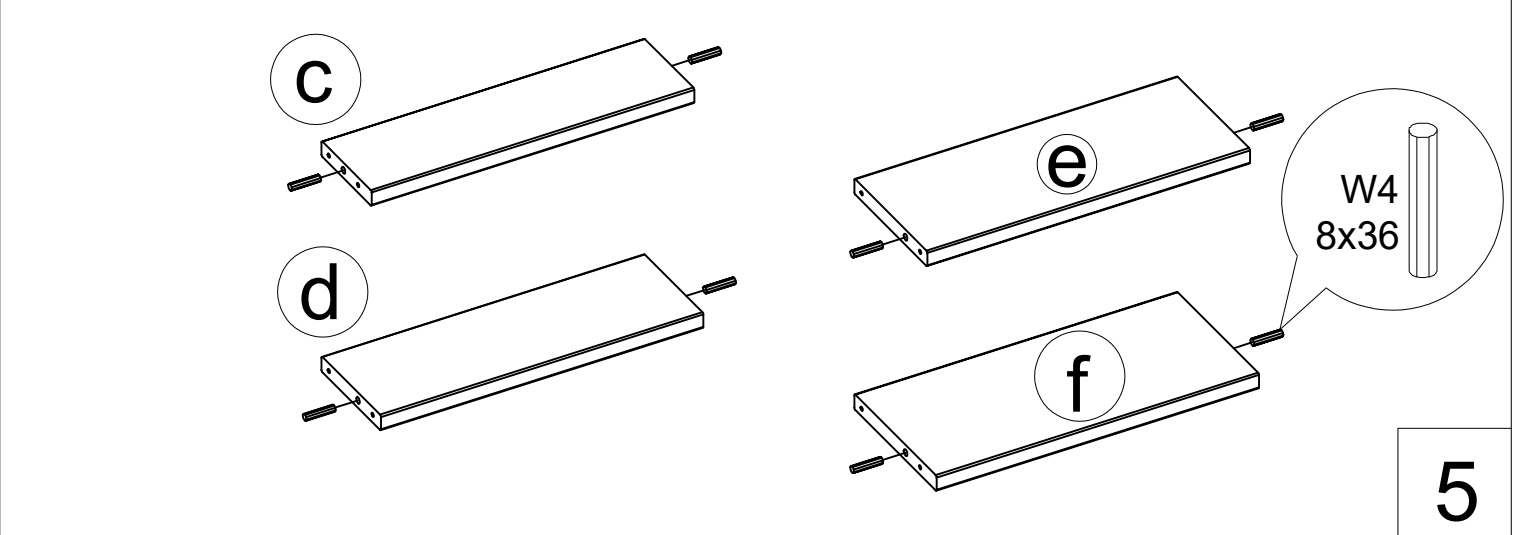
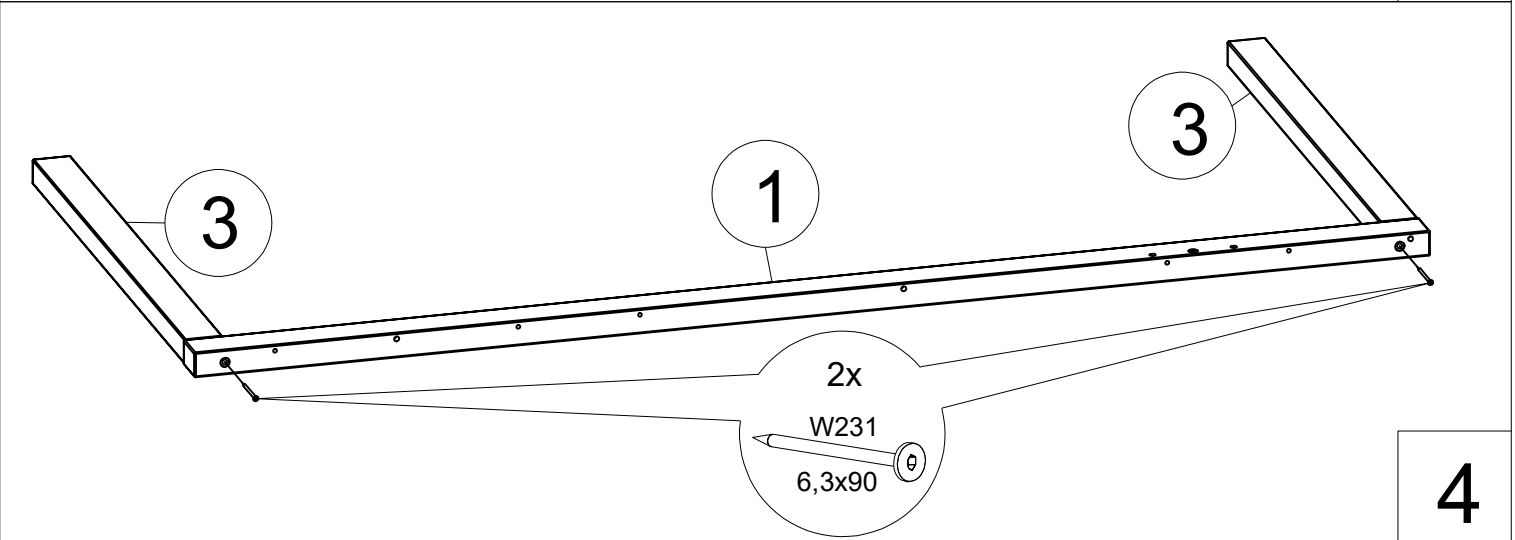
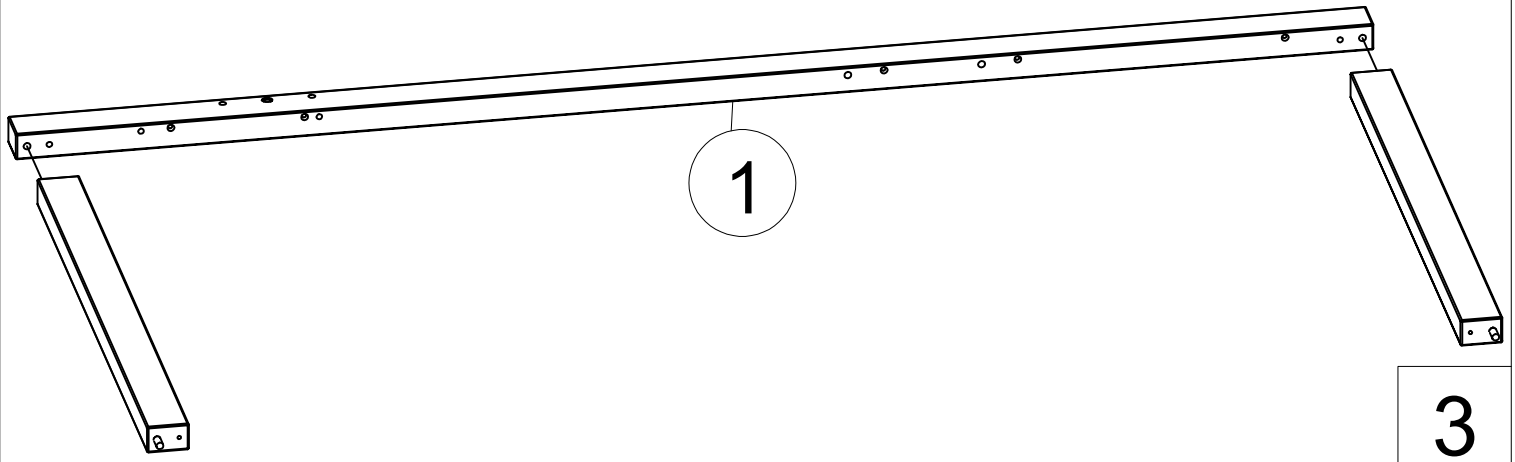

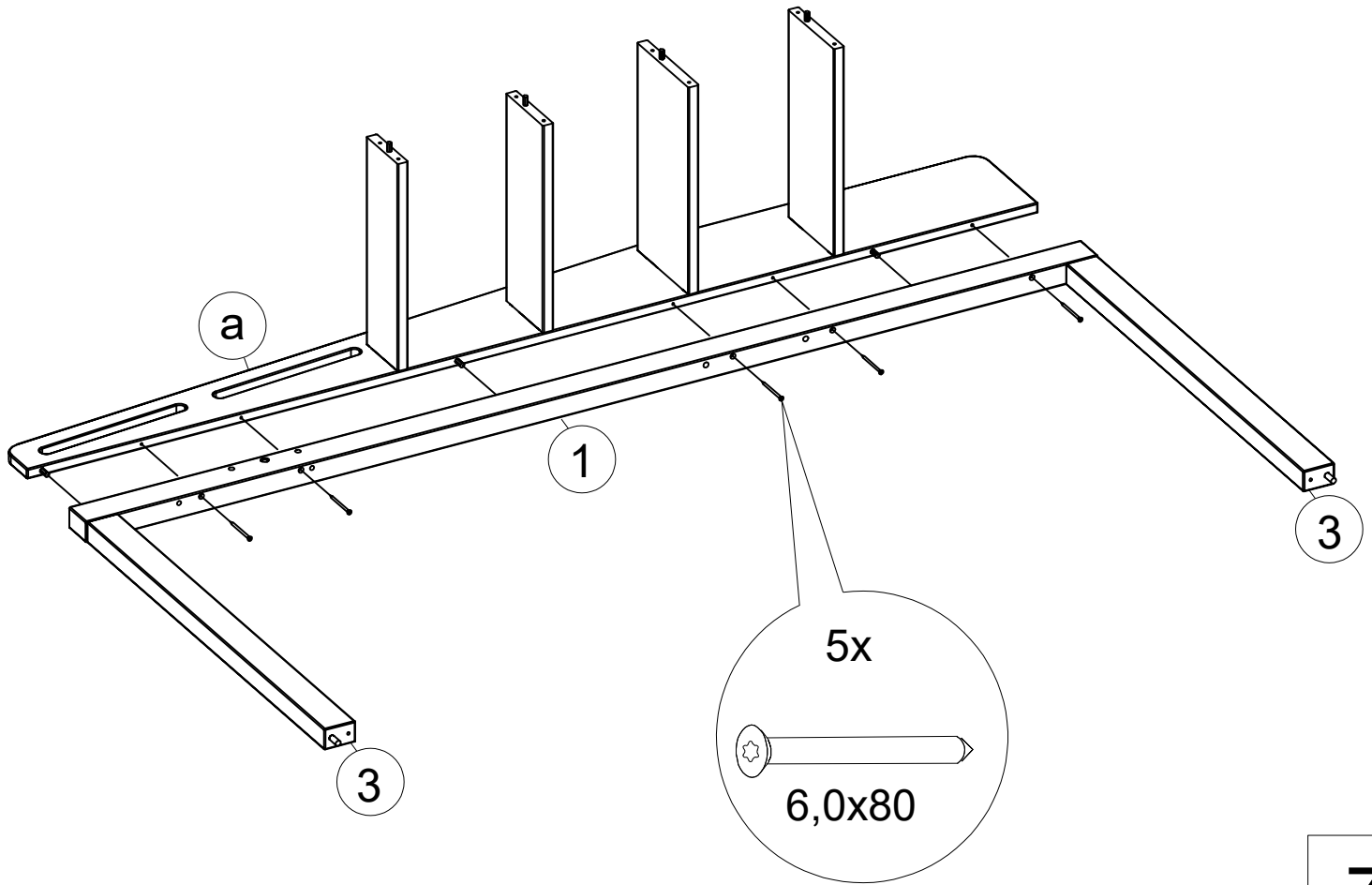

7

8

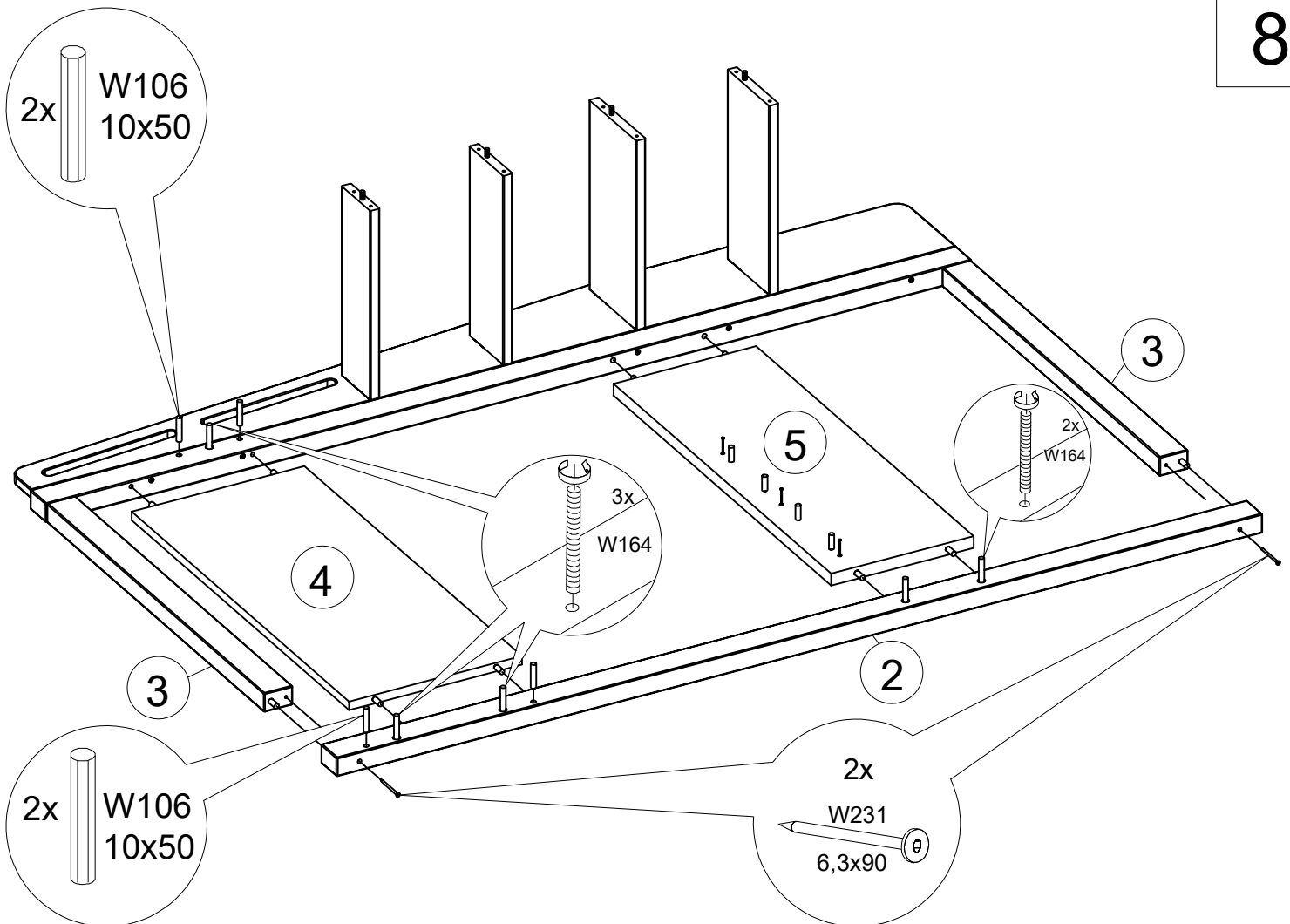

2x

W106
10x50

2x

W106
10x50

3x

W164

2x

W231
6,3x90

2x

W164

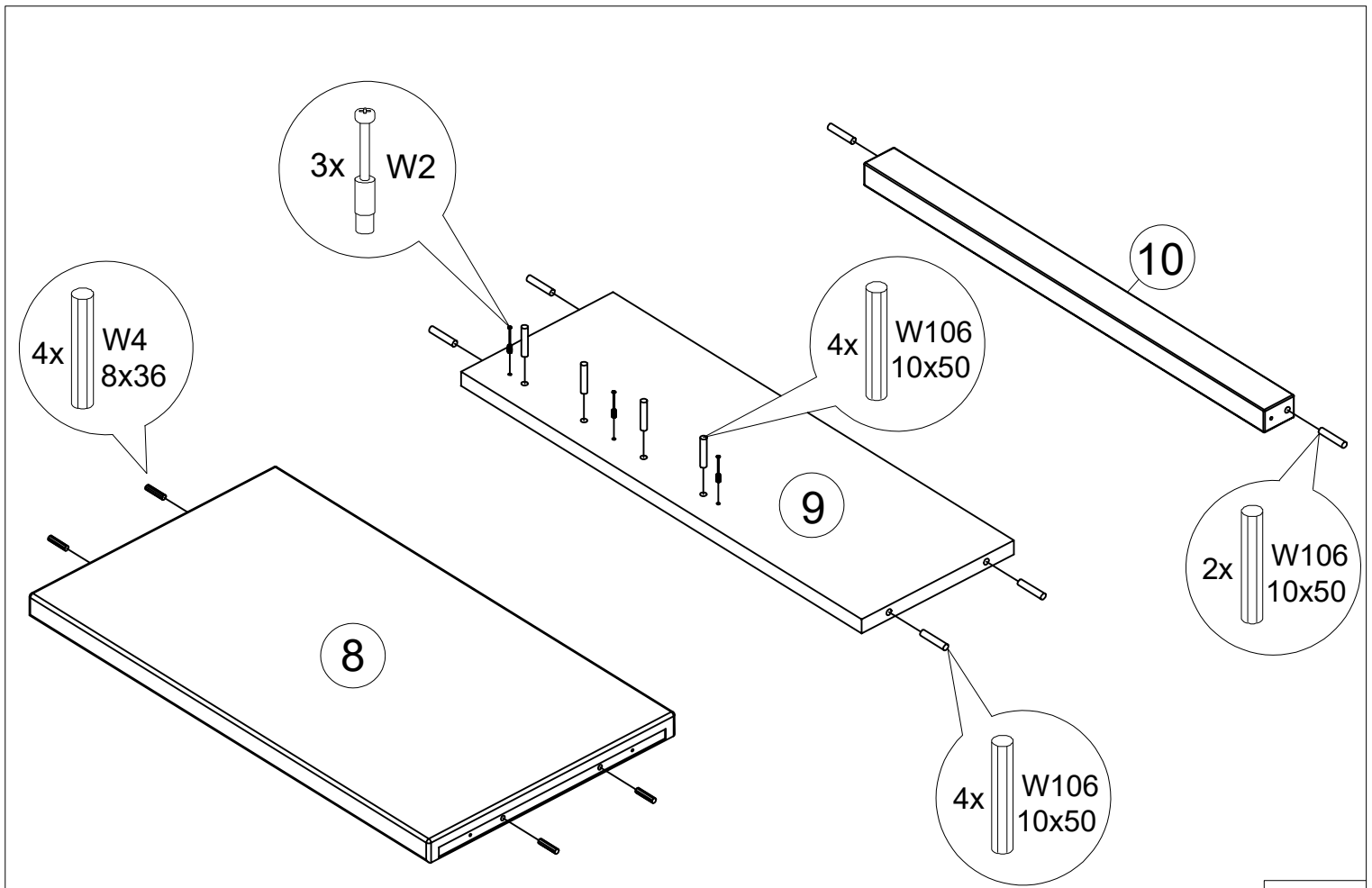

9
10

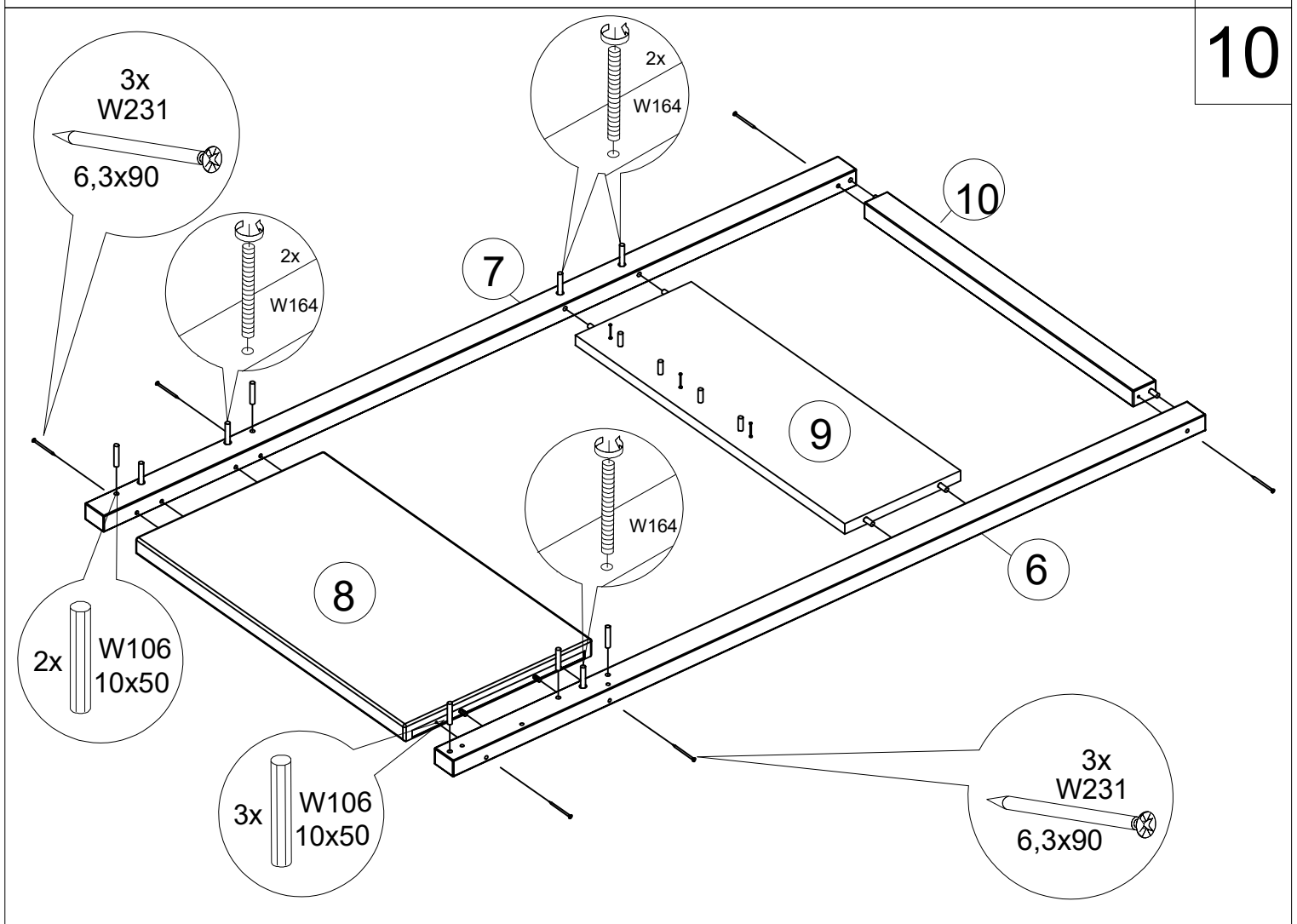

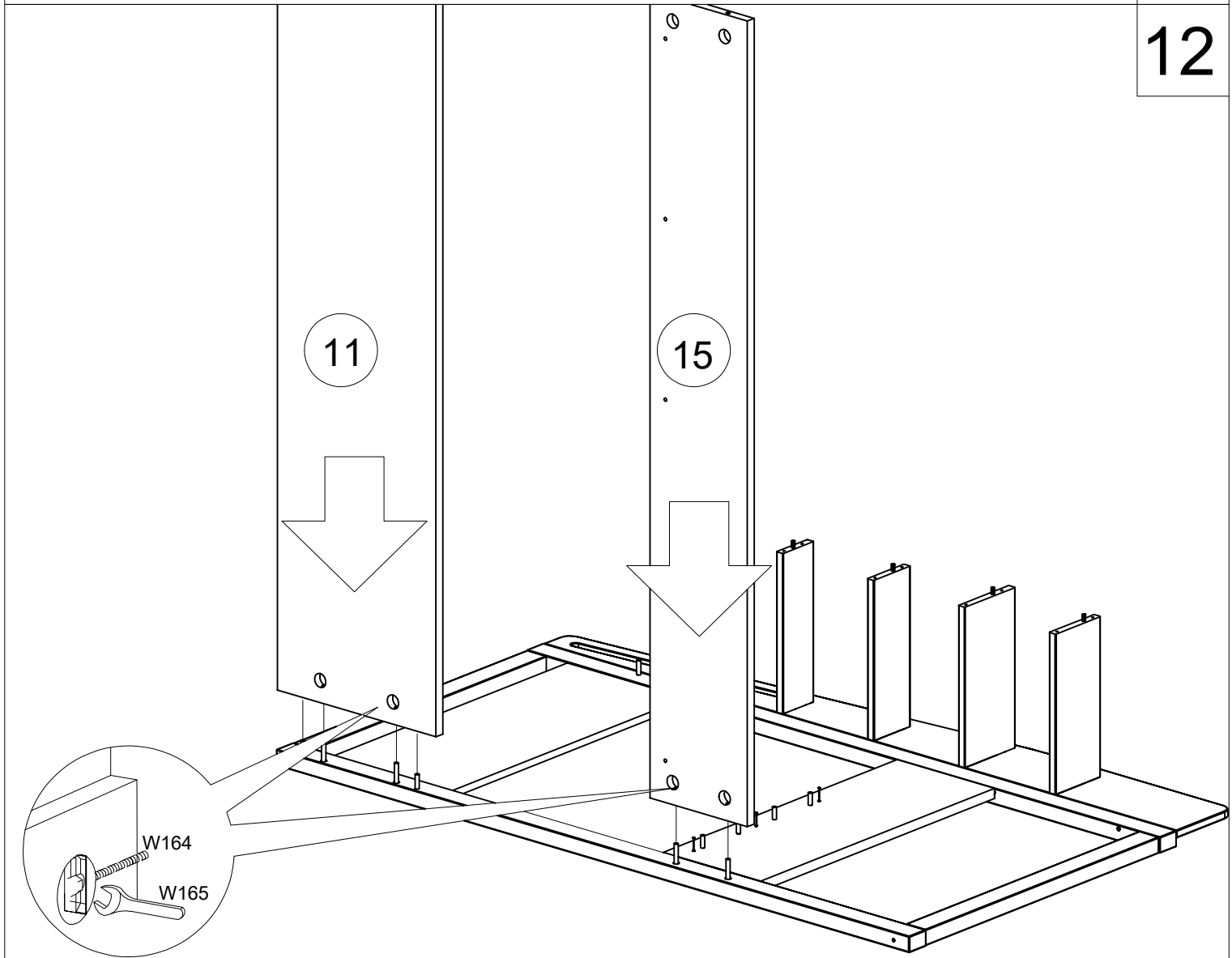
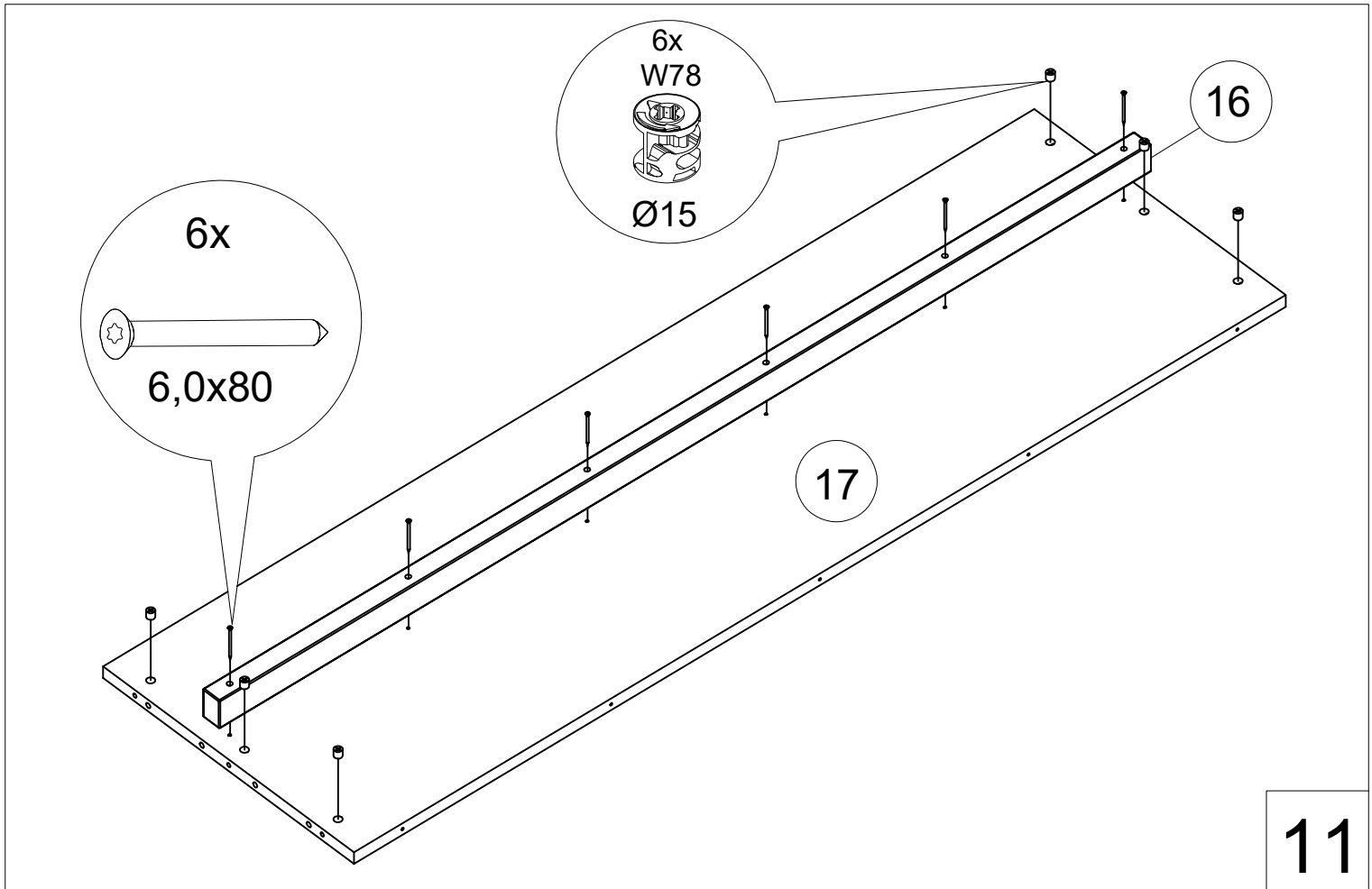

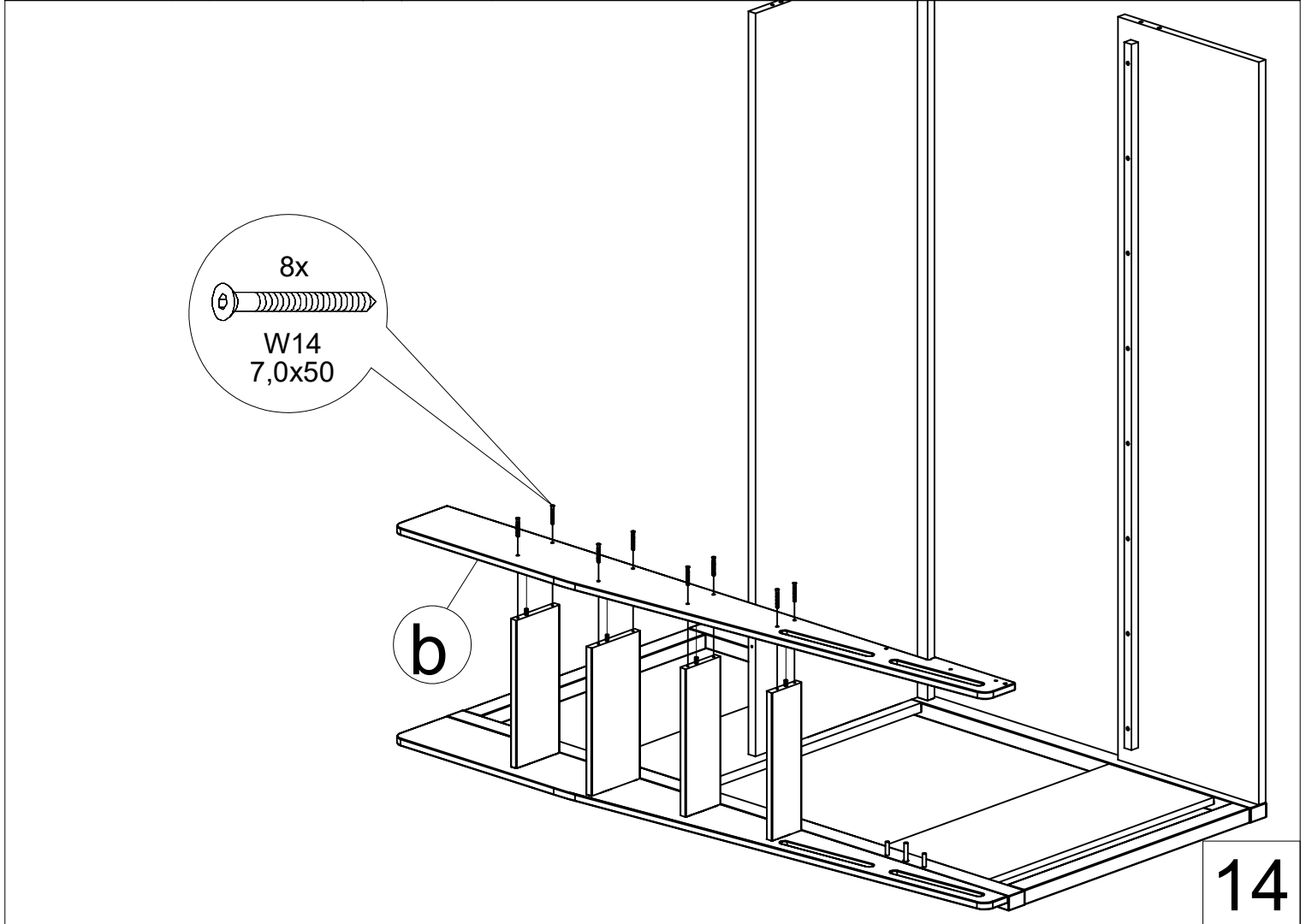
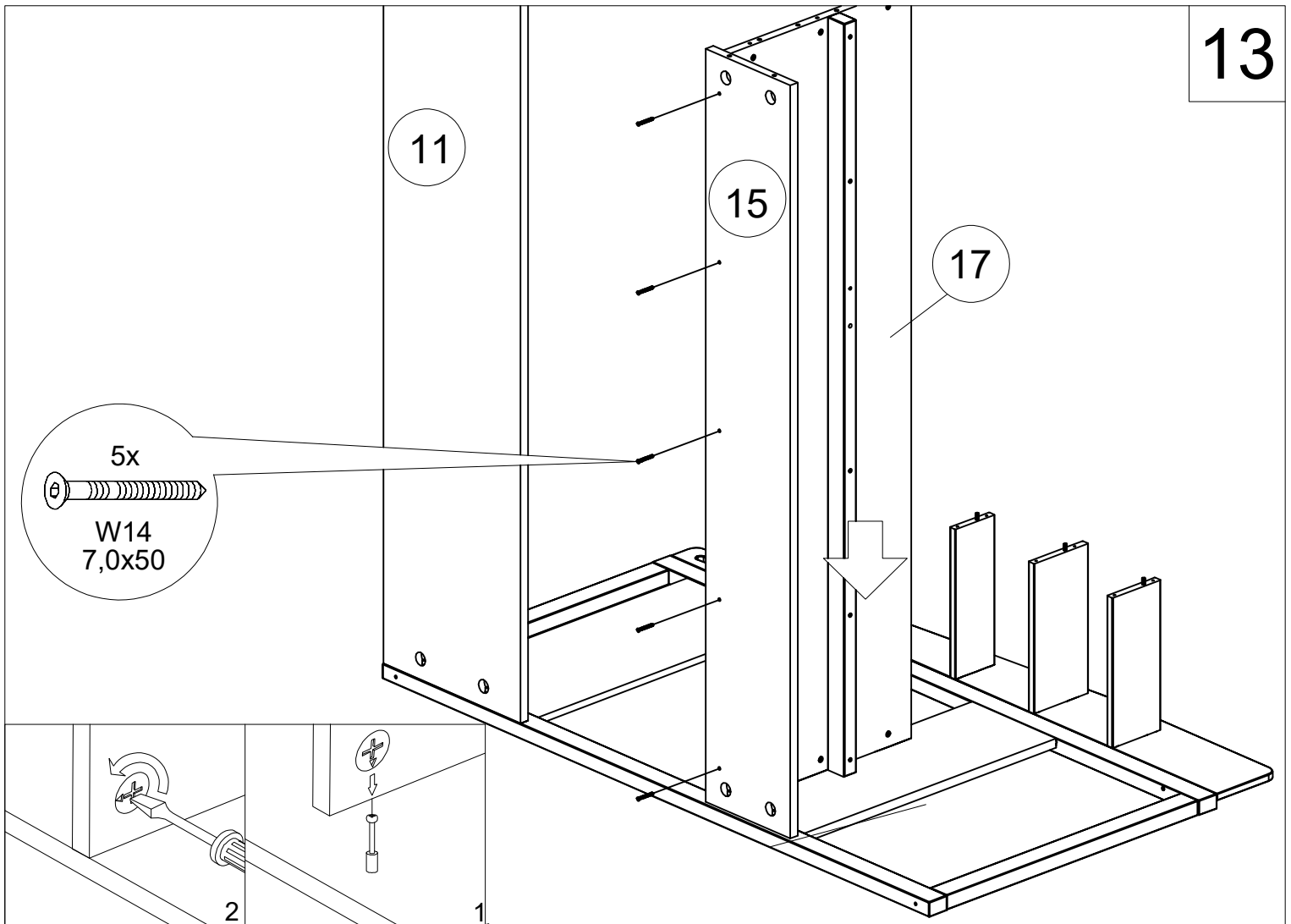

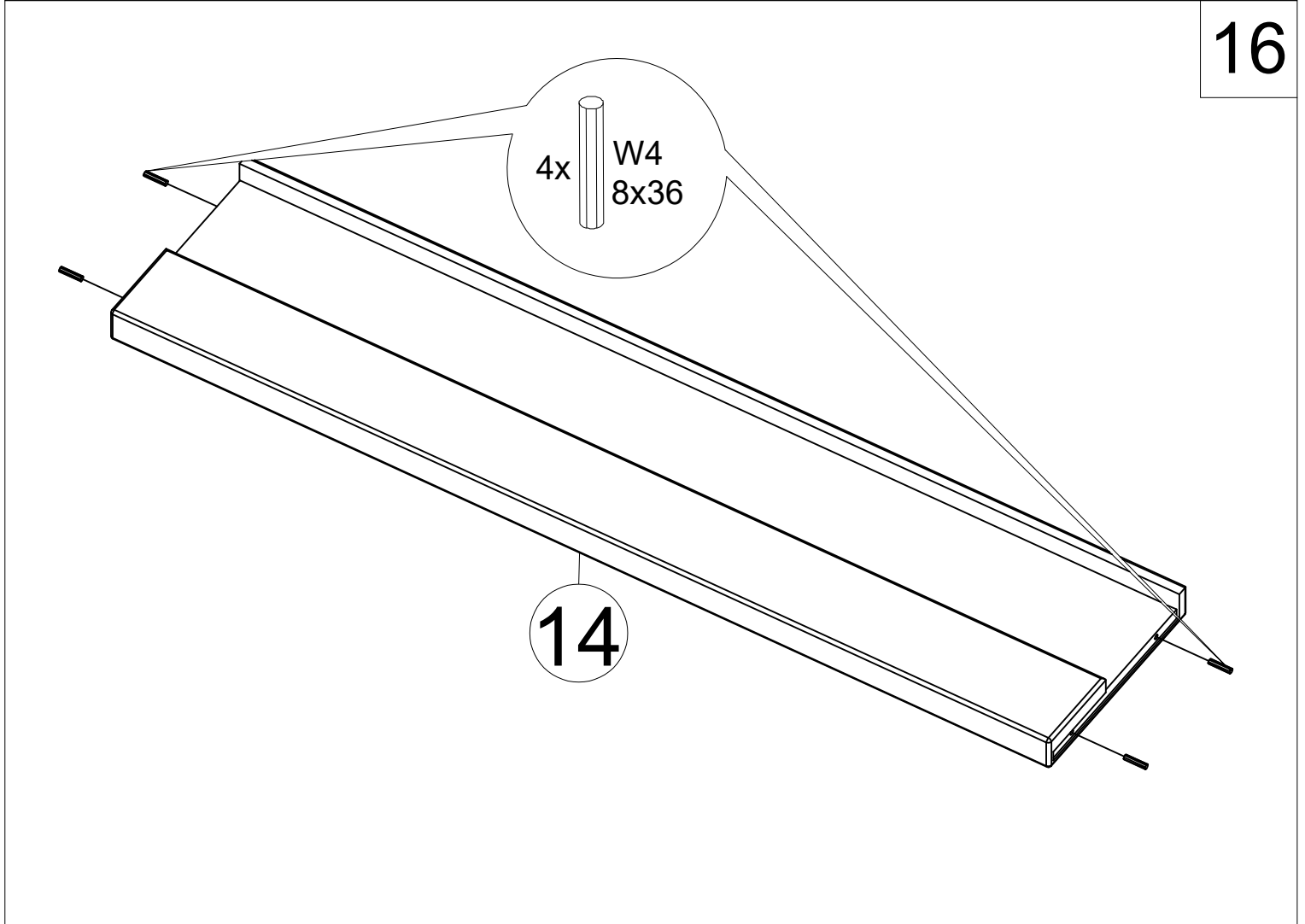
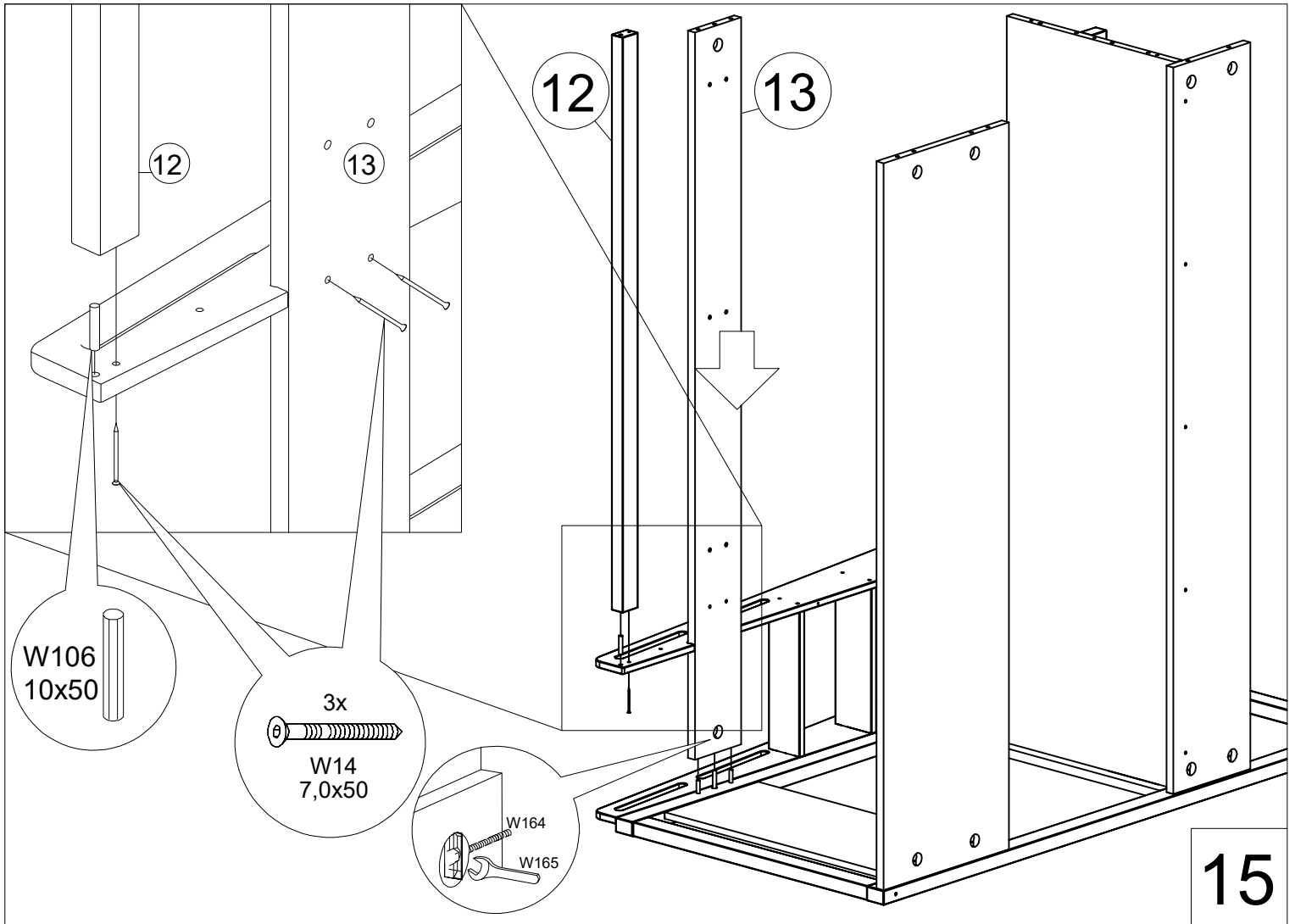

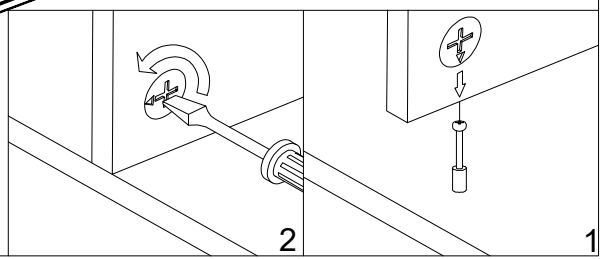
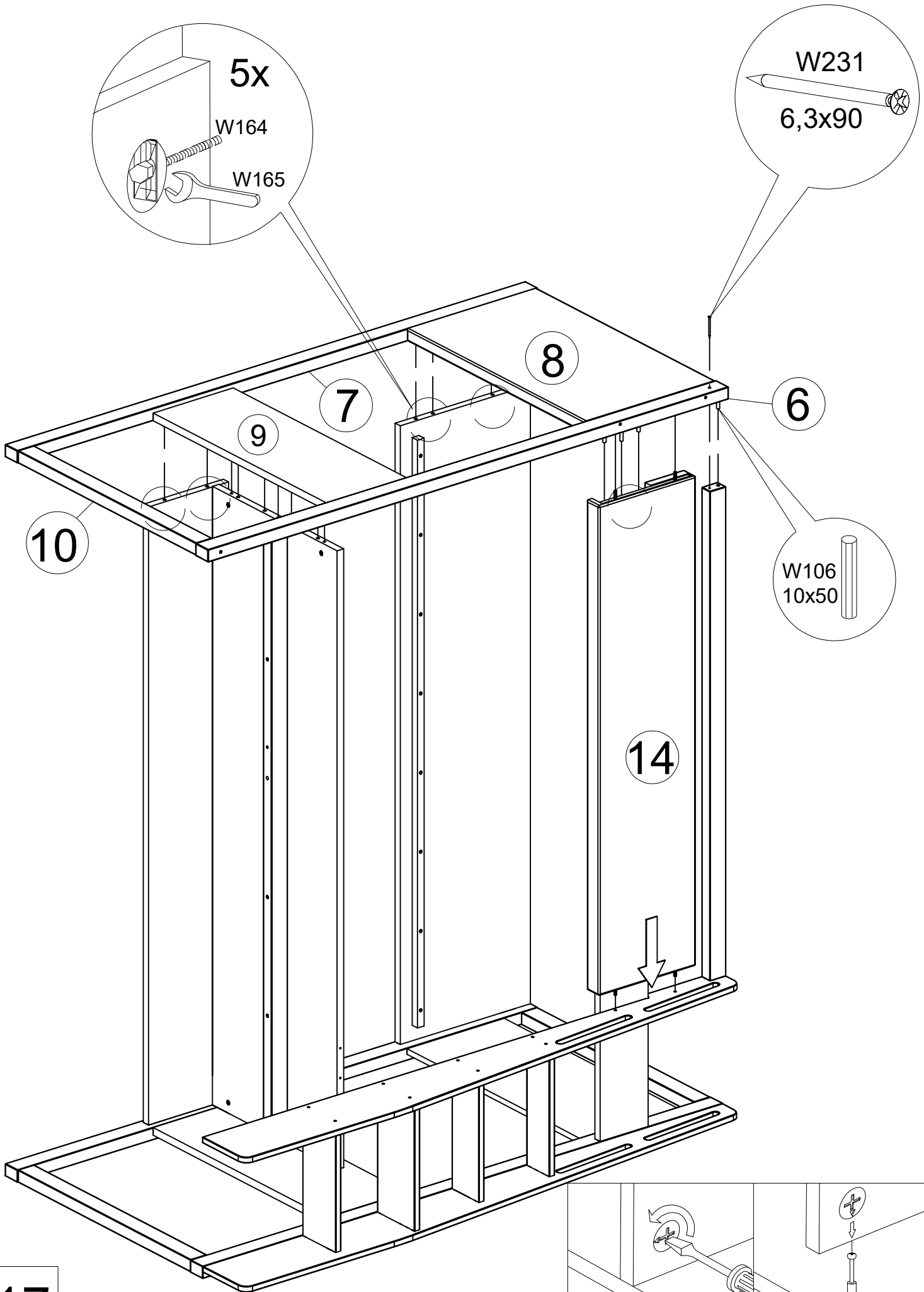

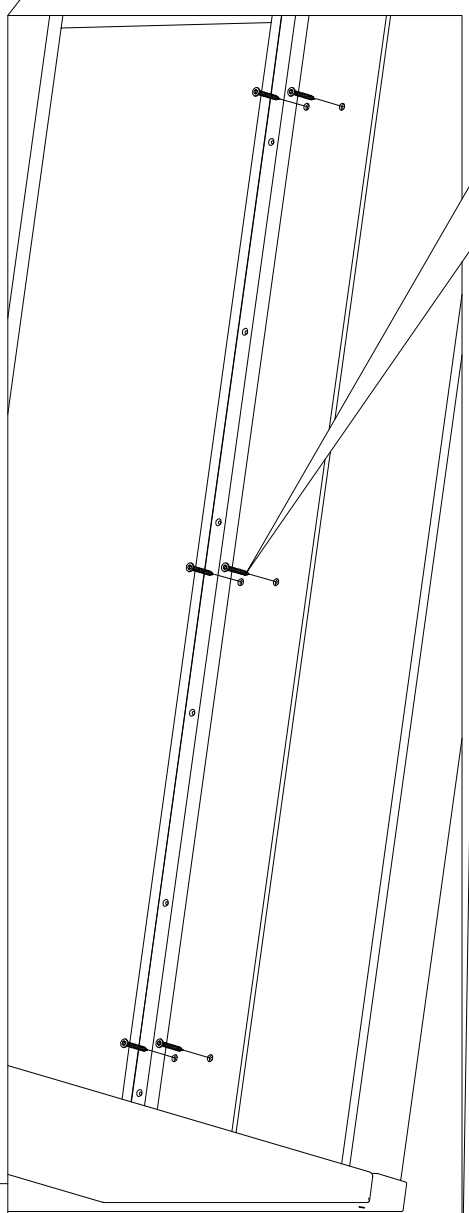
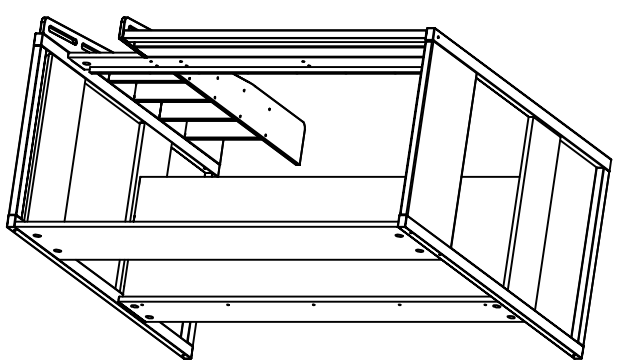
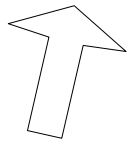
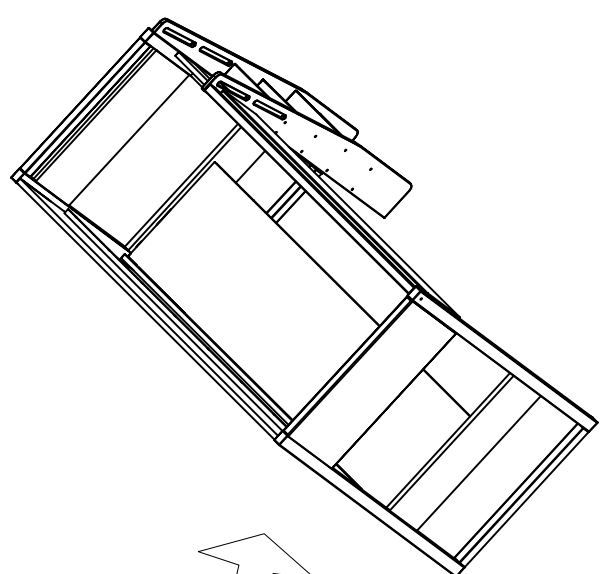
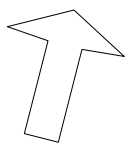
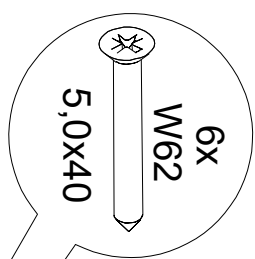
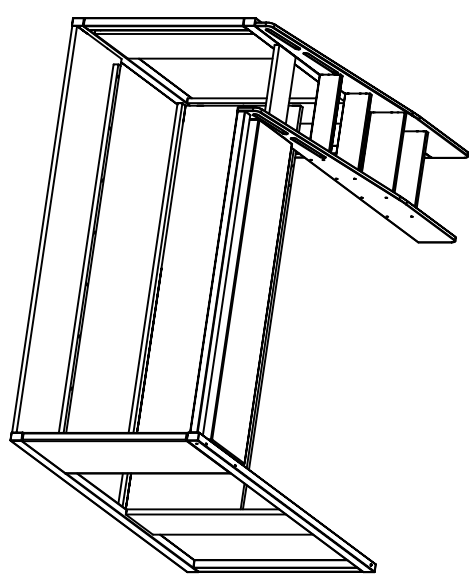
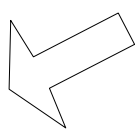
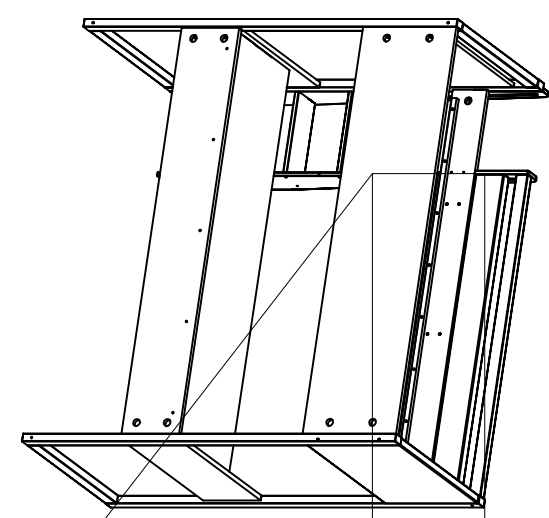
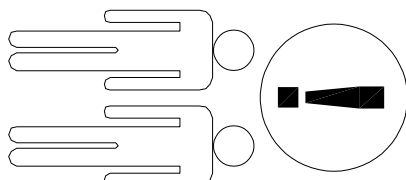

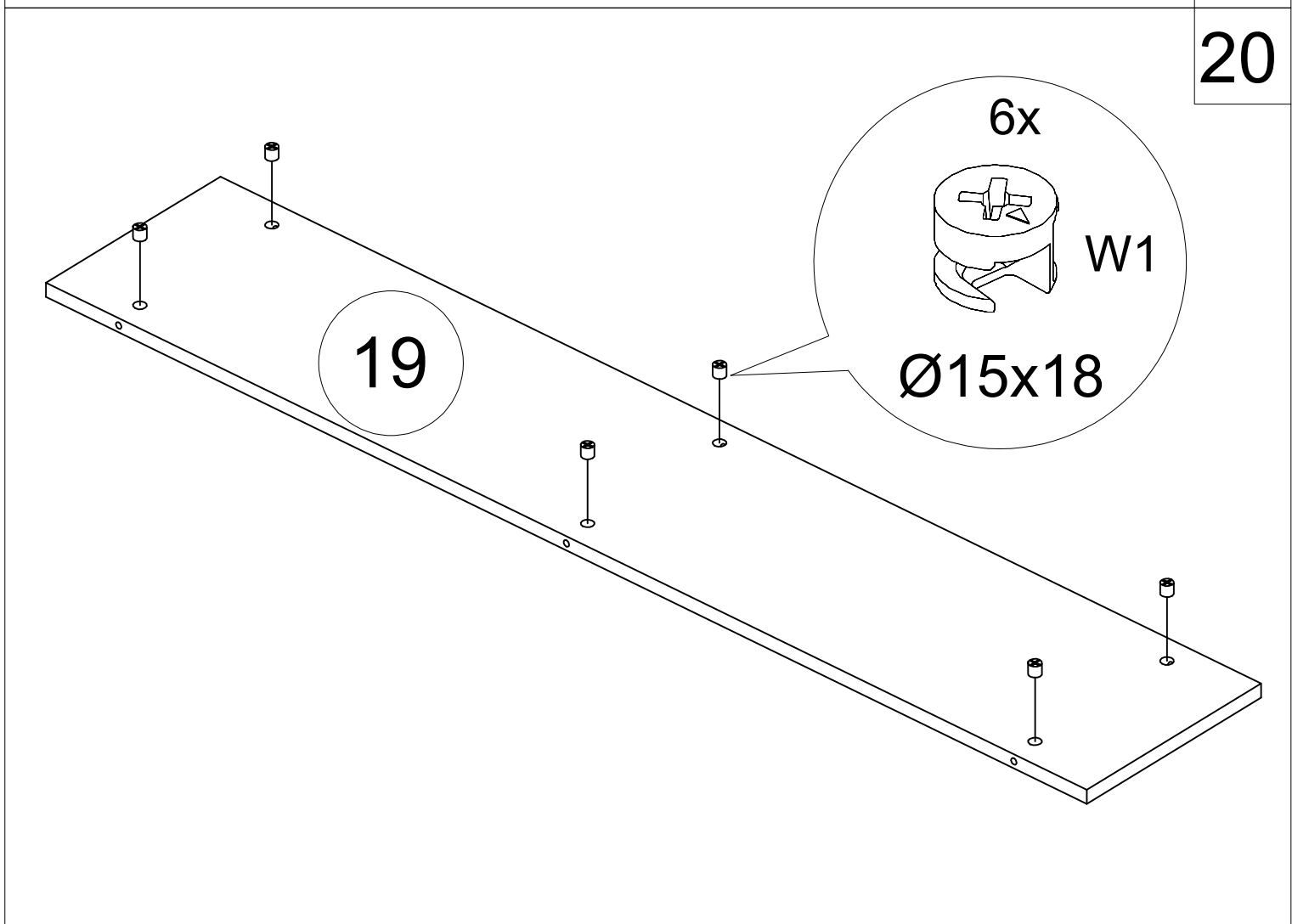
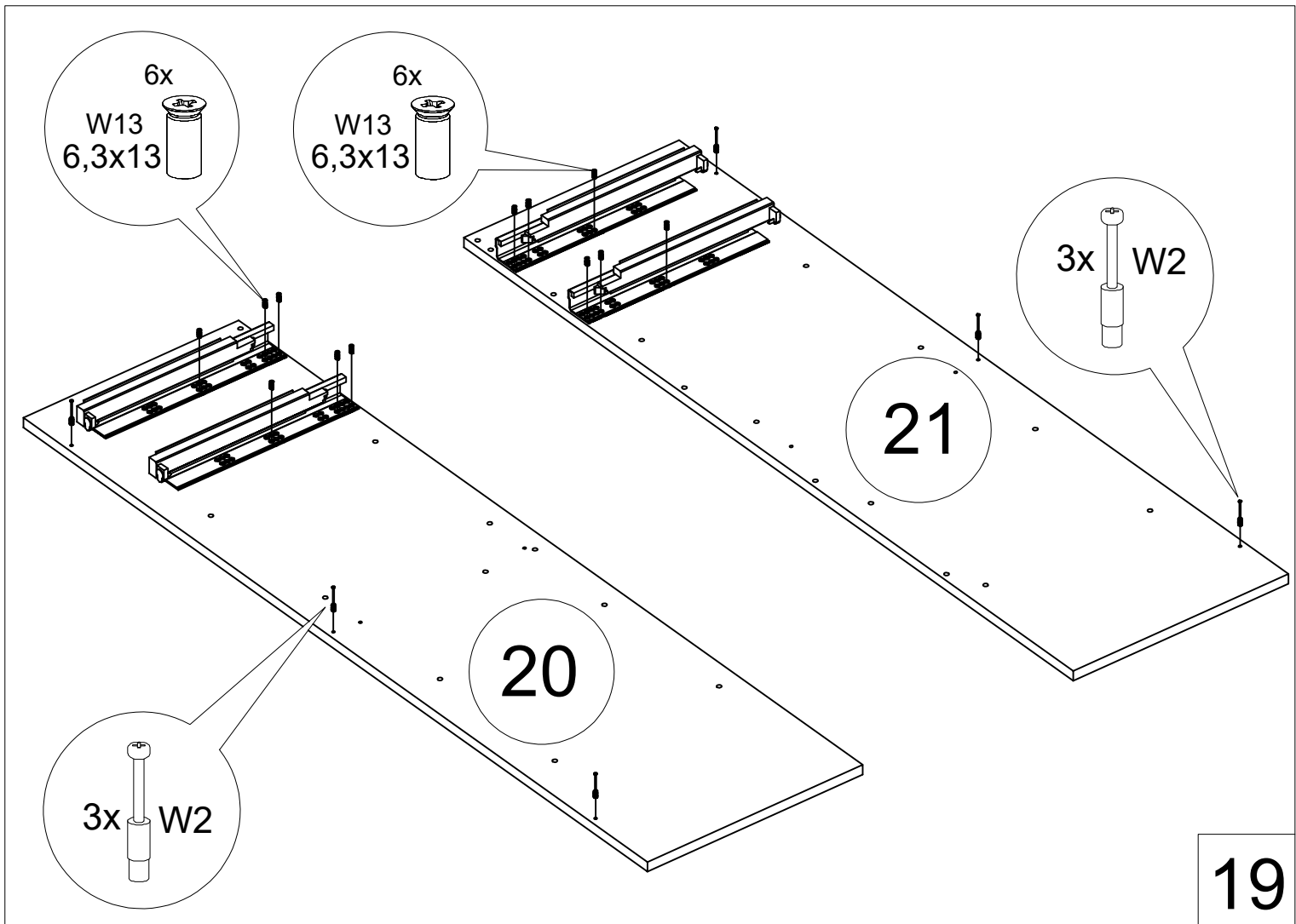

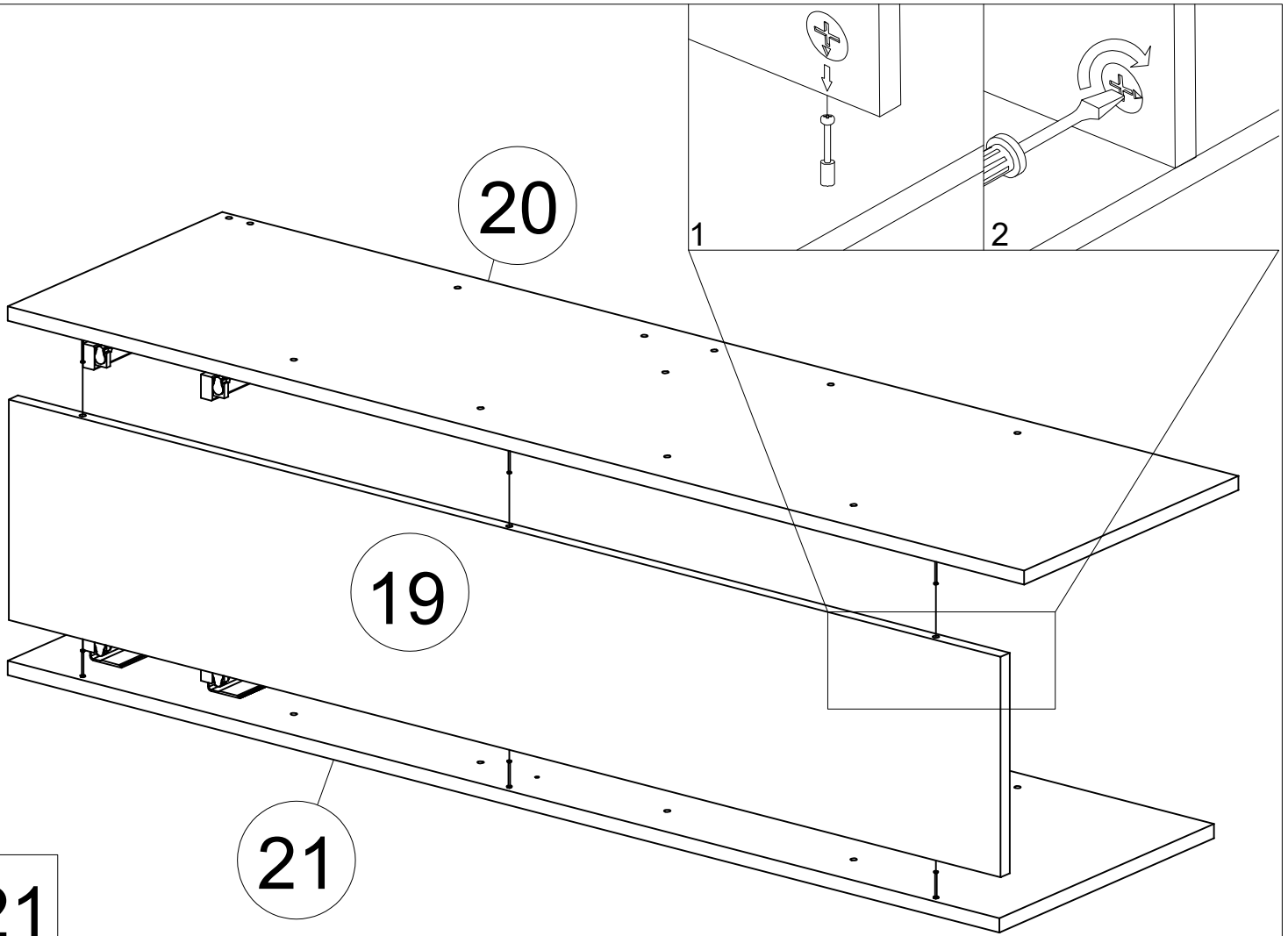

21

22

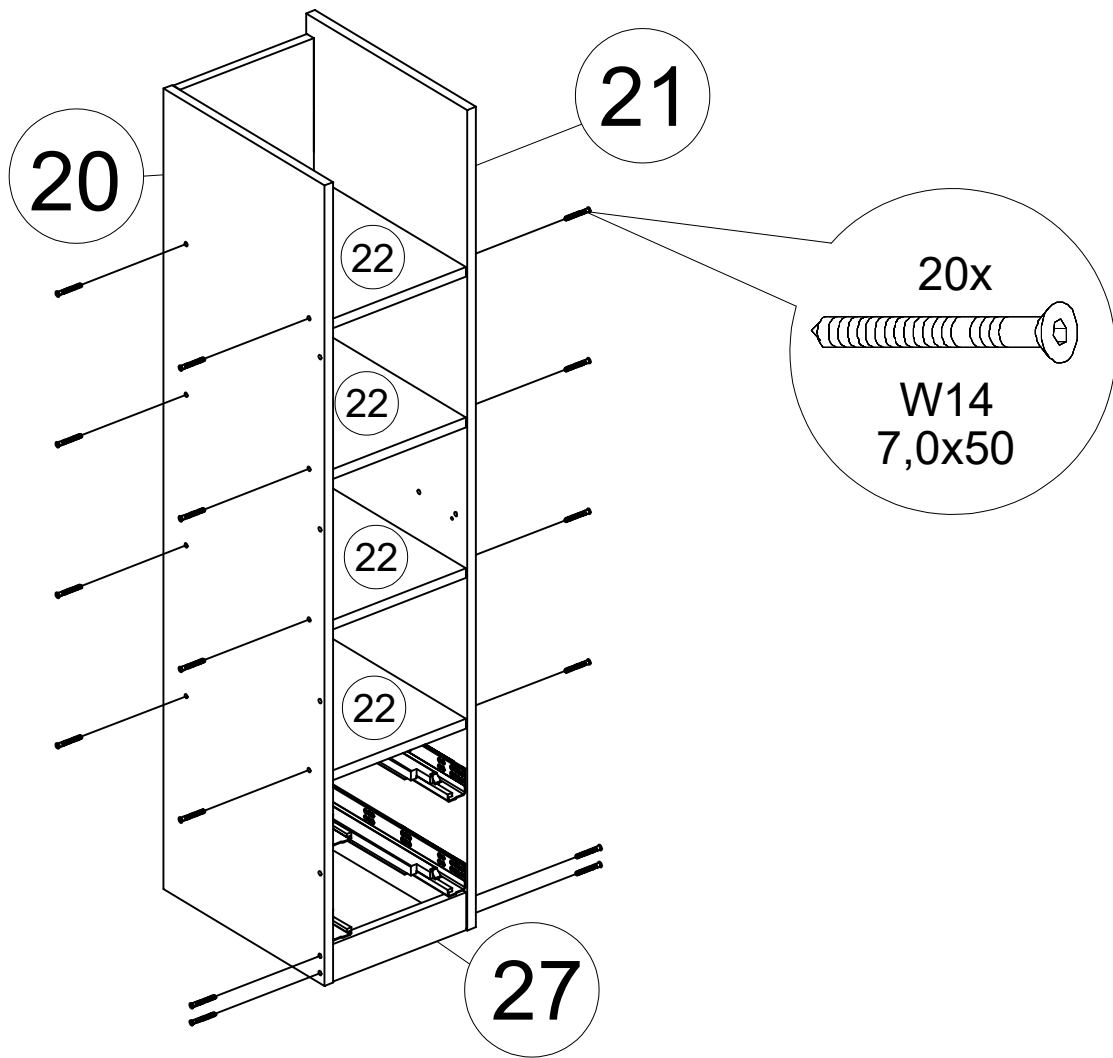

23

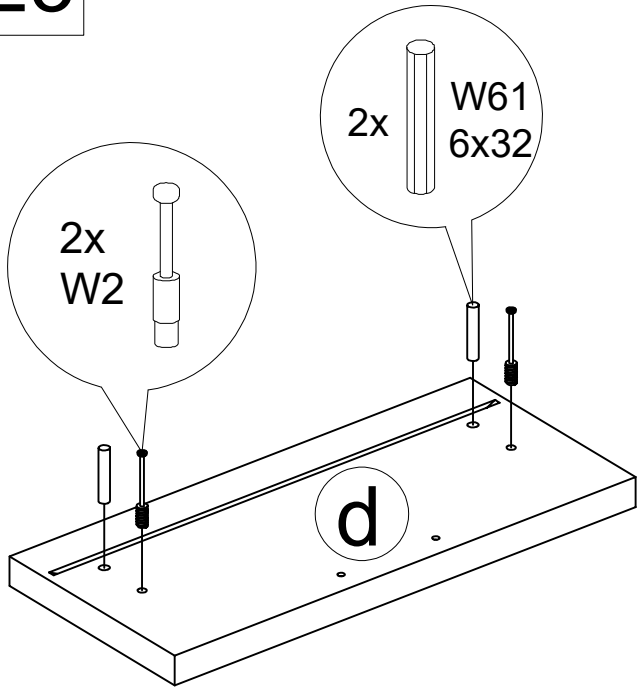

24

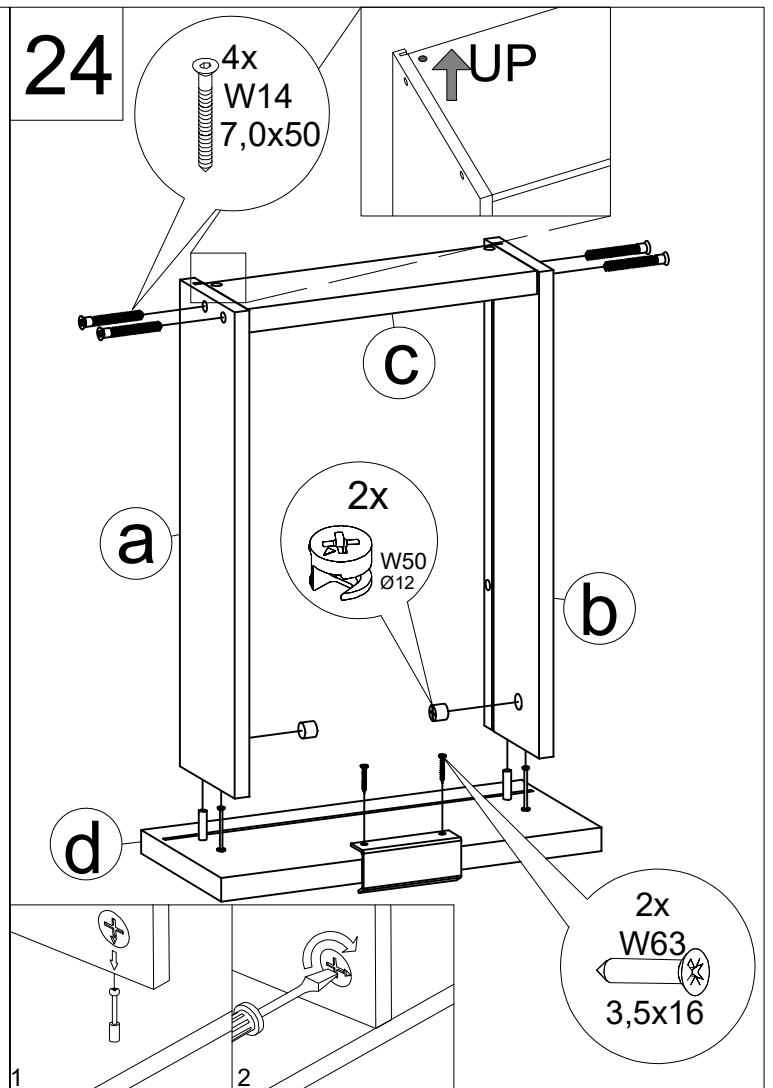

25

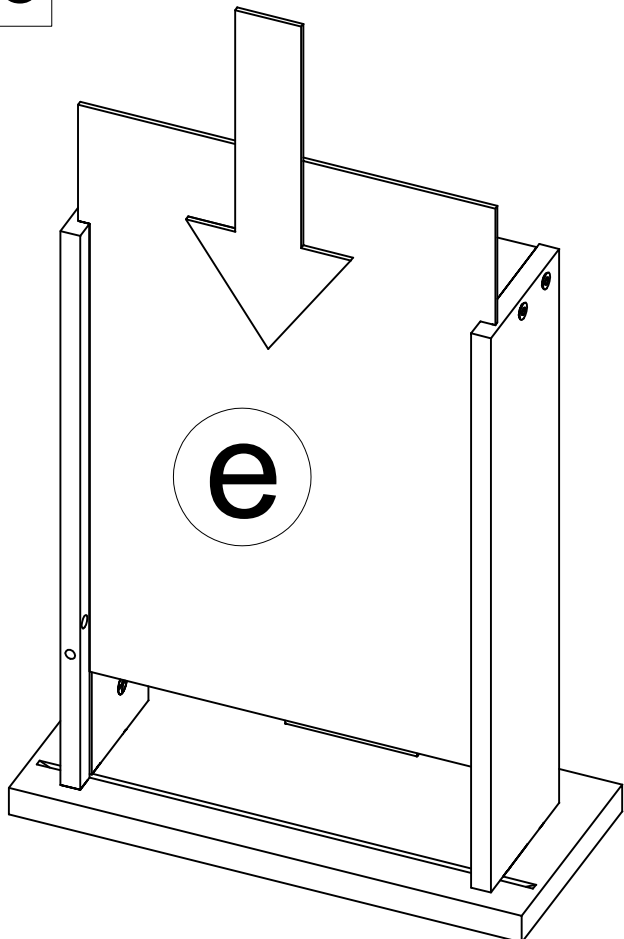

26

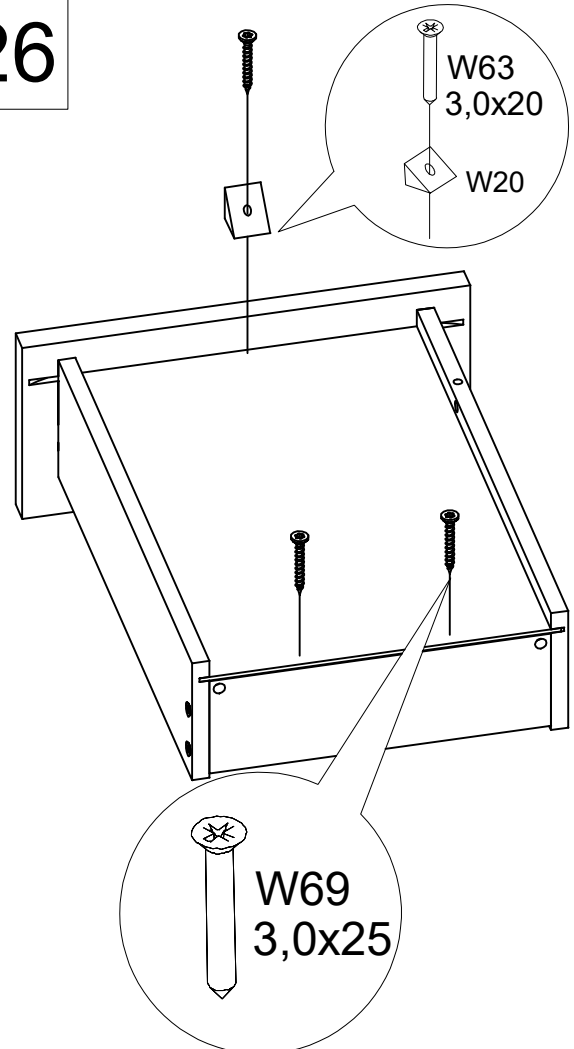

27

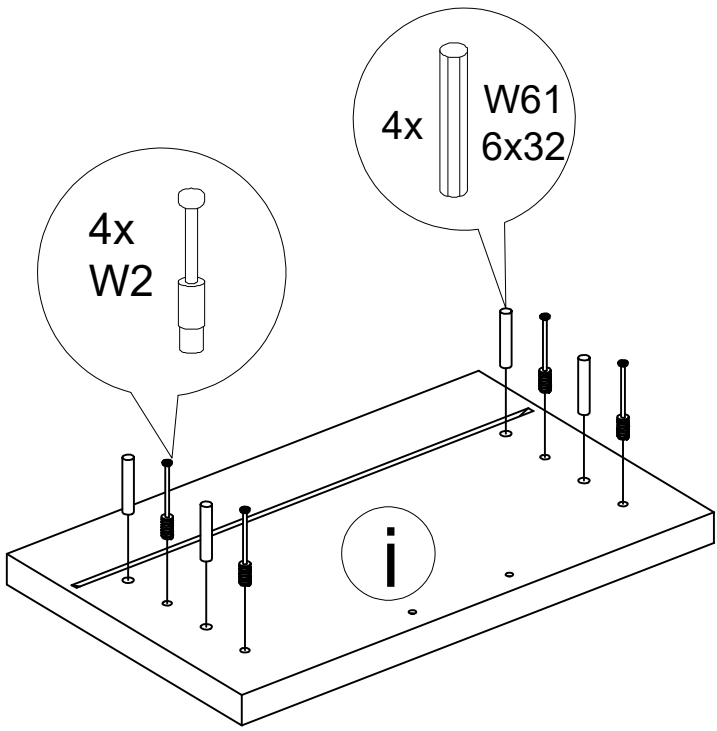

28

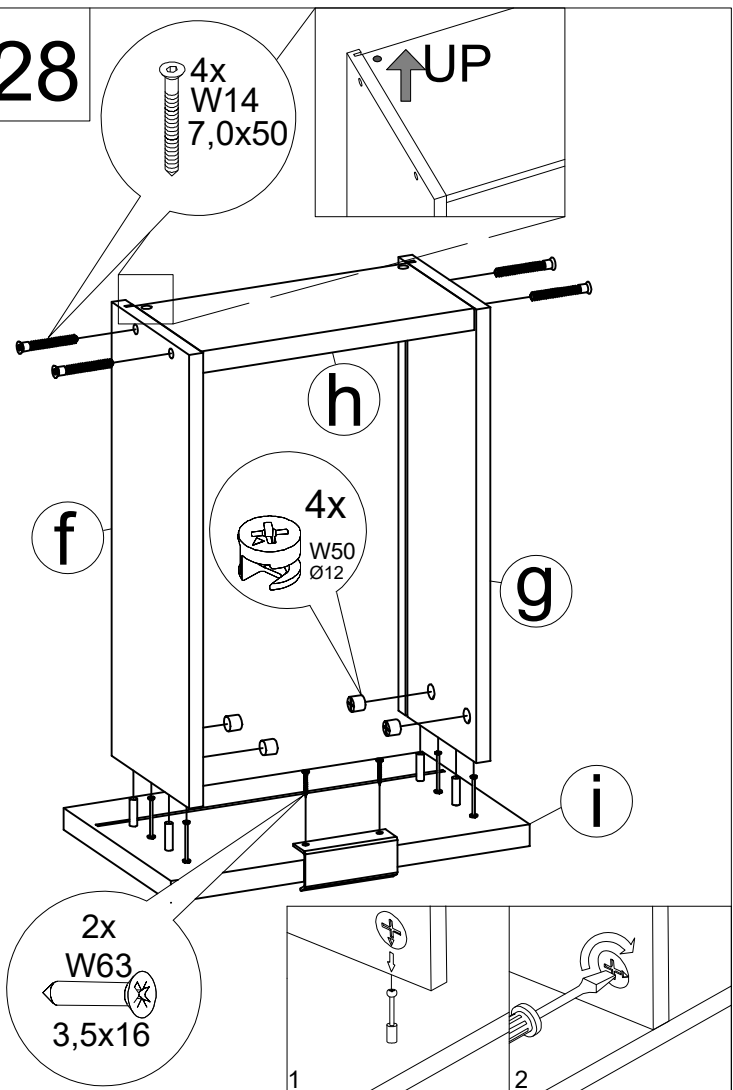

29

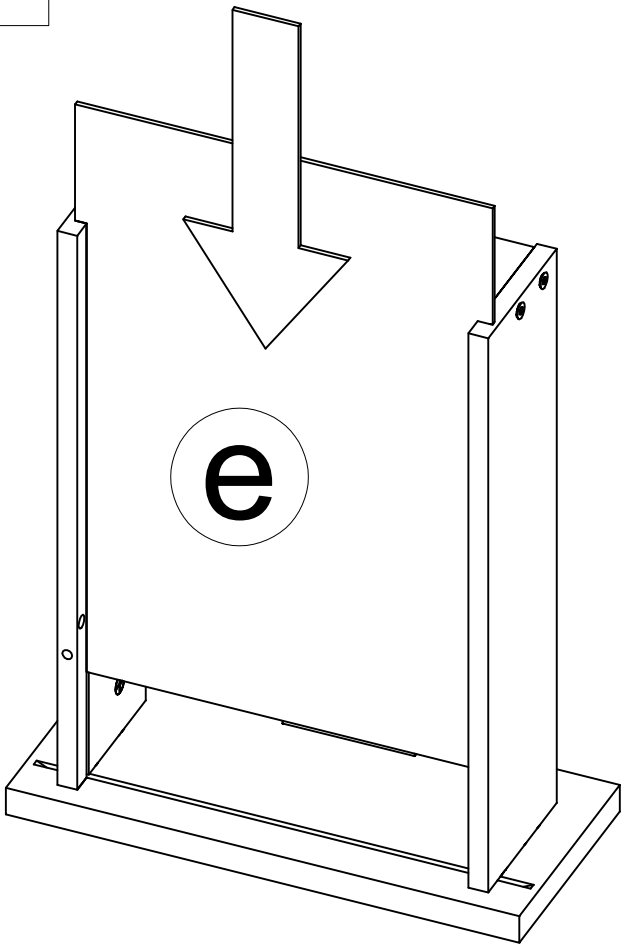

30

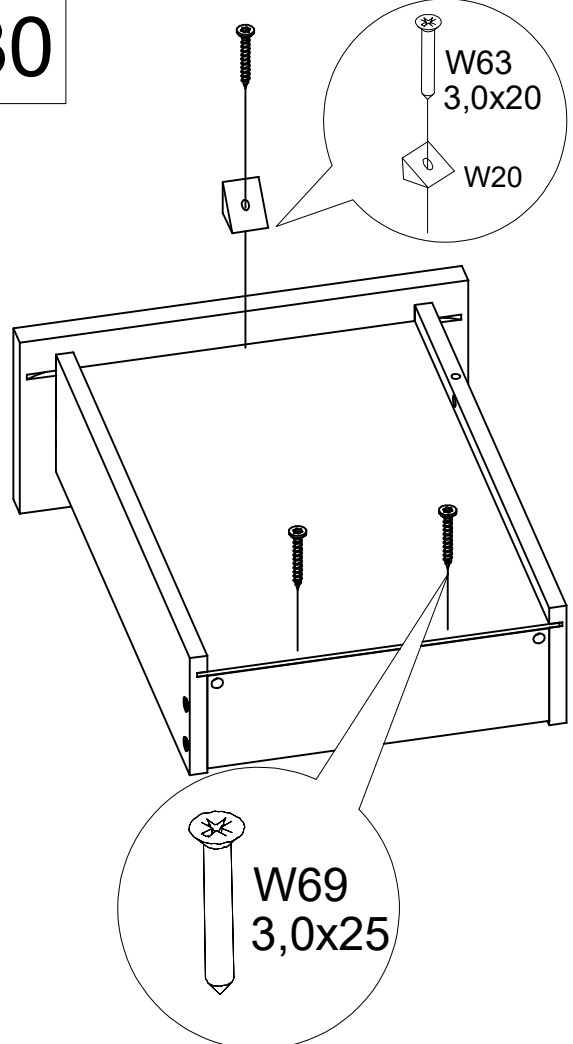

32

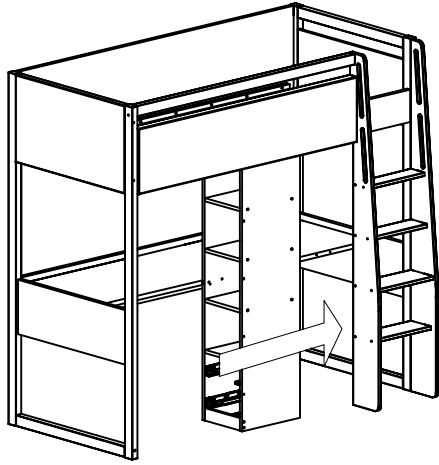

31

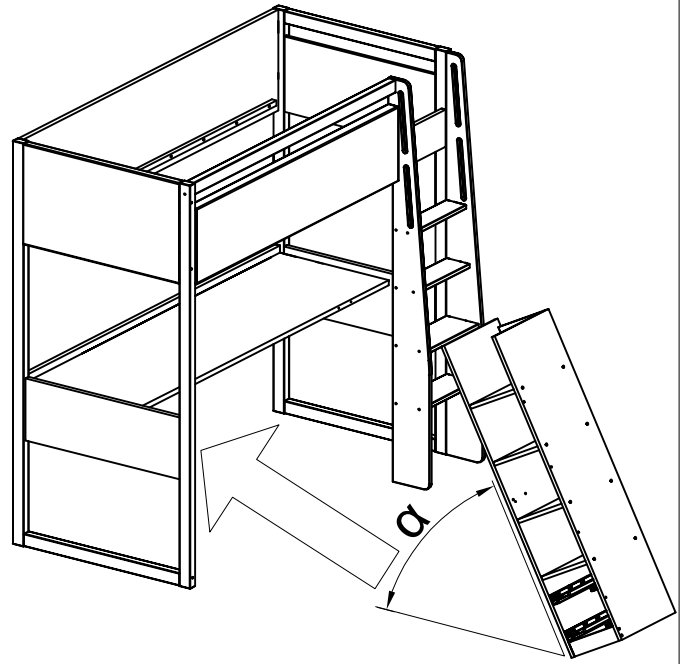

33

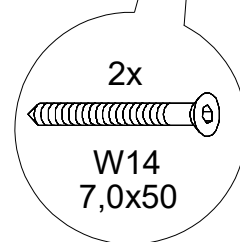
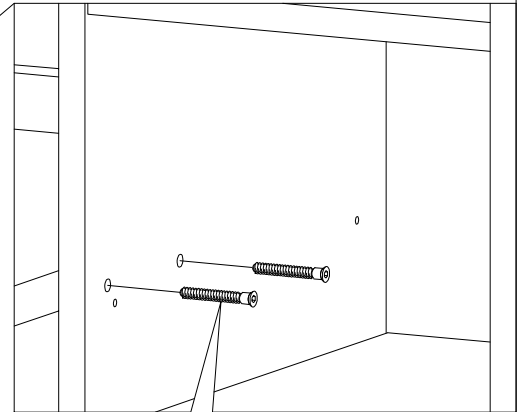
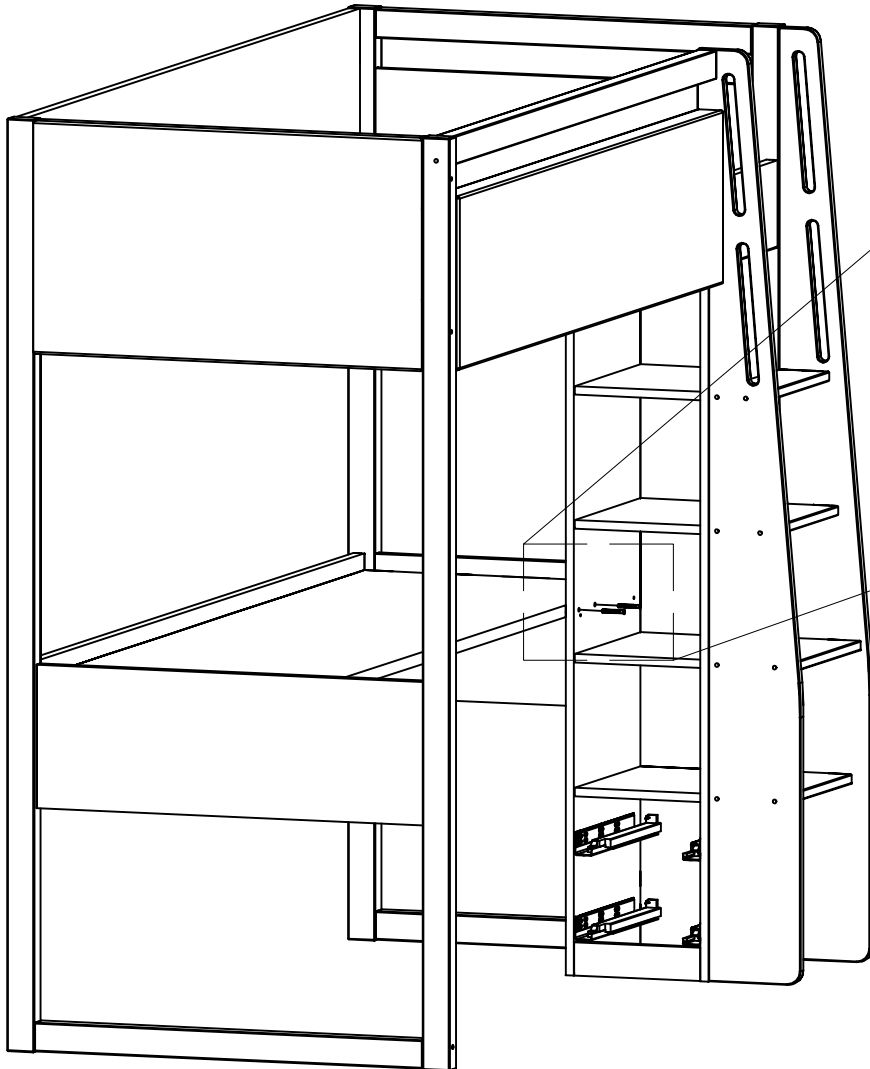
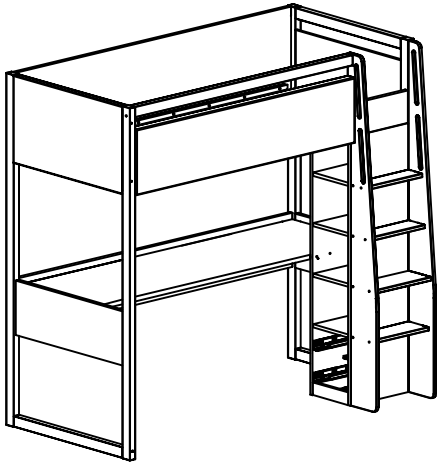

34

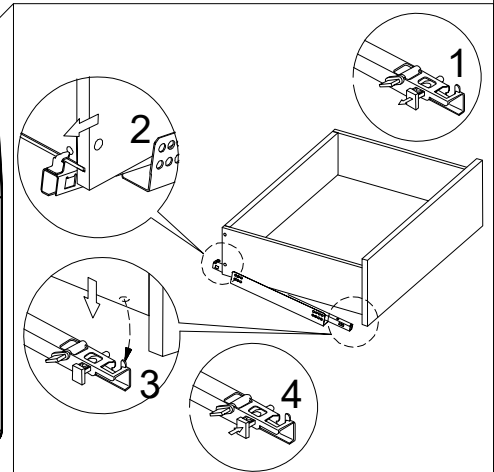
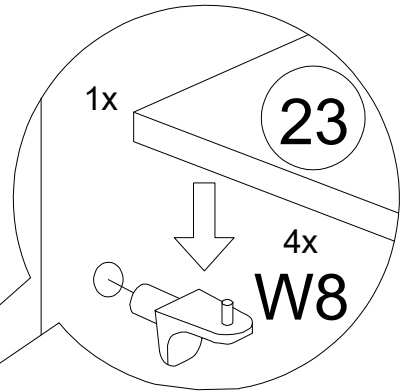
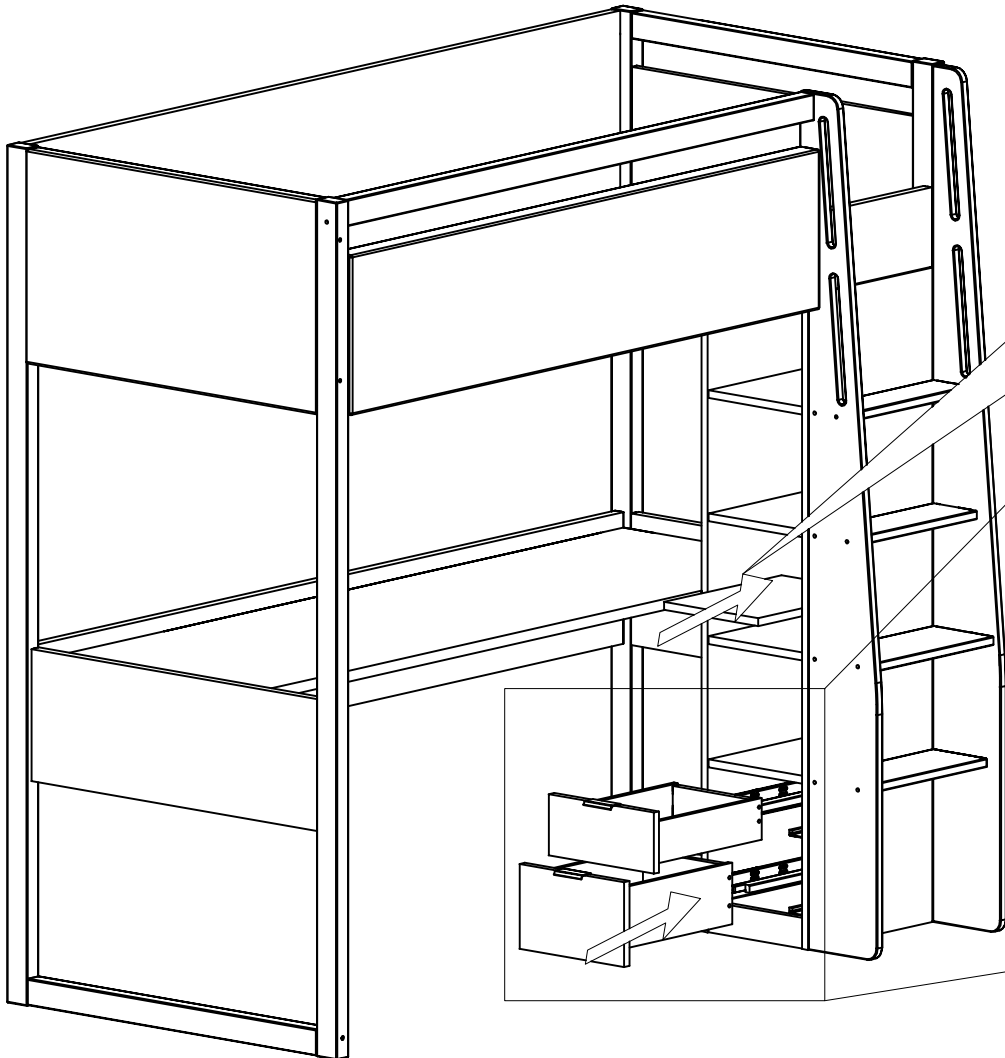
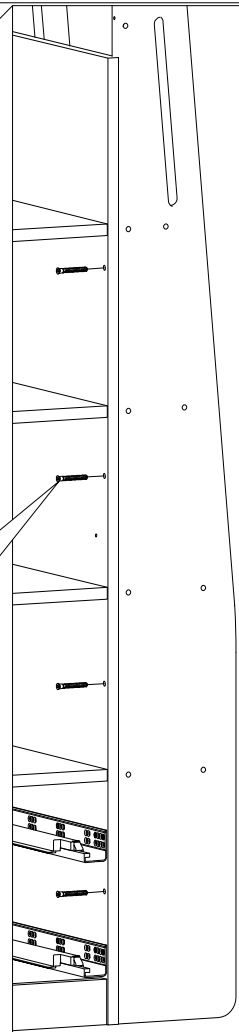
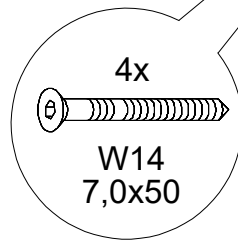
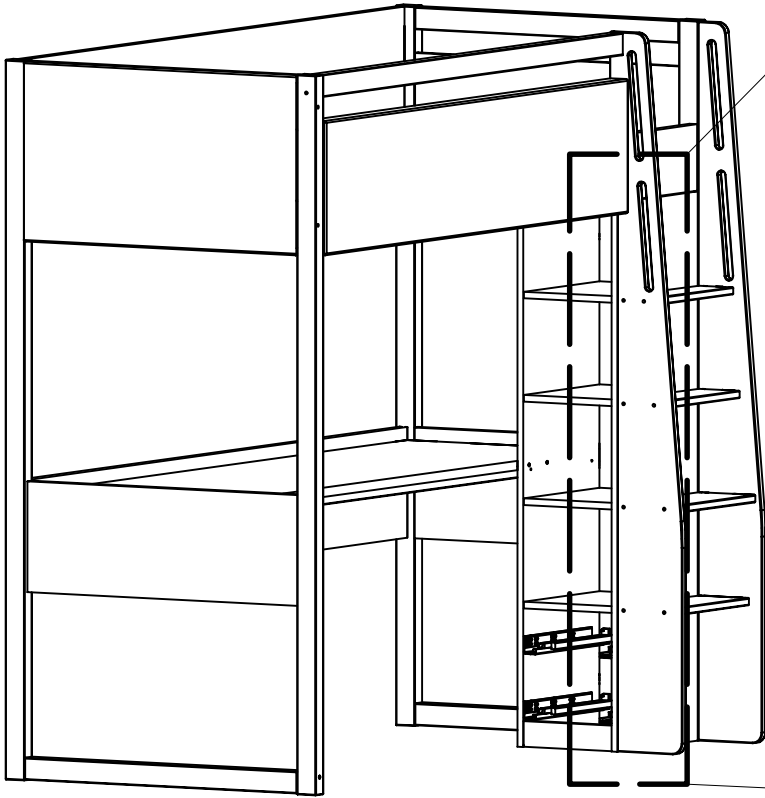

1)

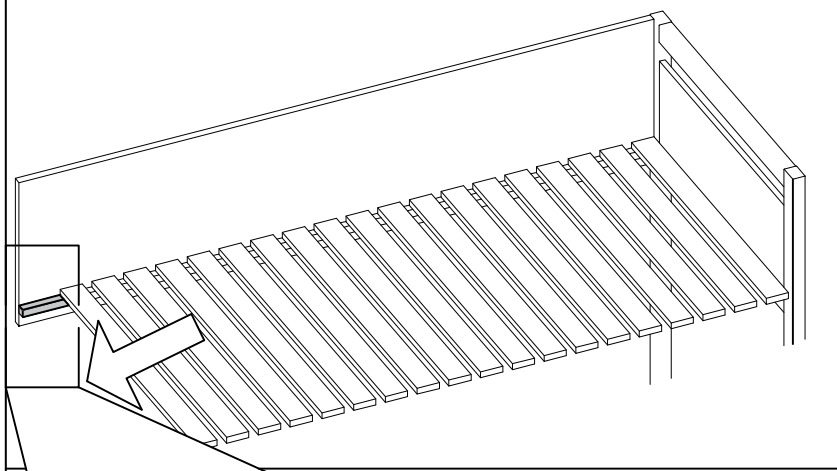

2)

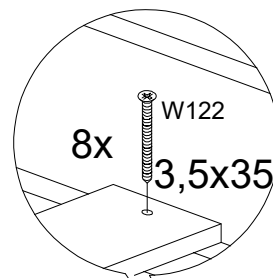
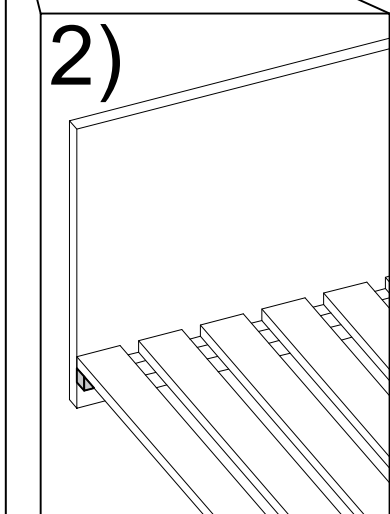

8

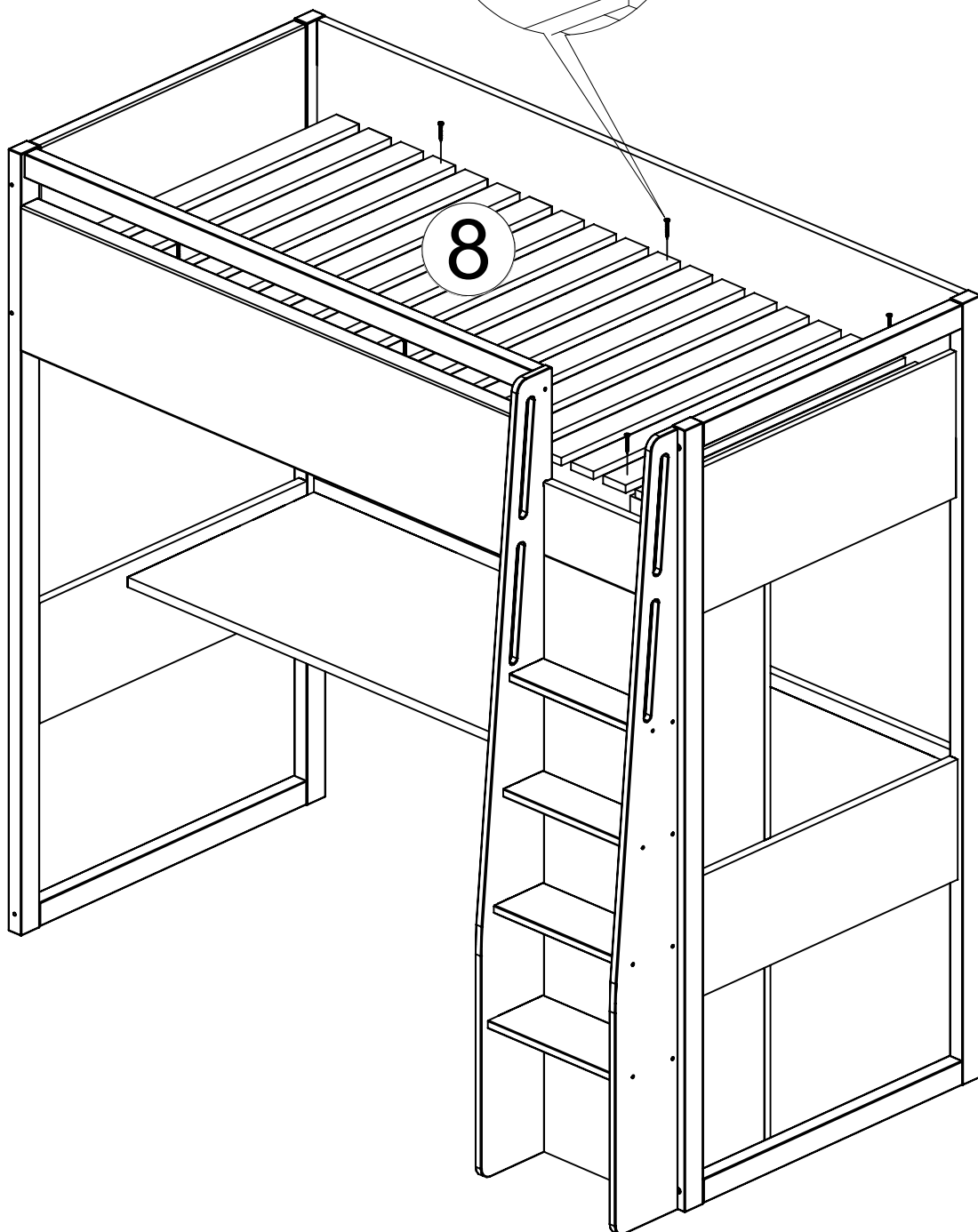

1)

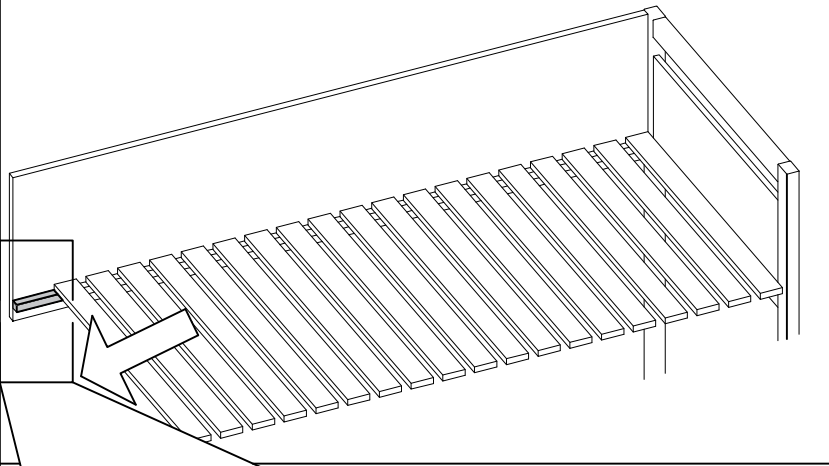

2)

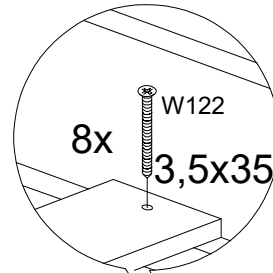
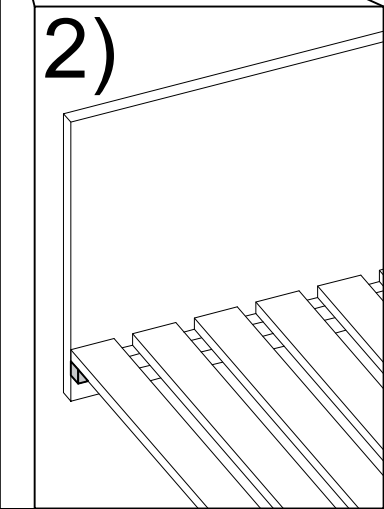

8

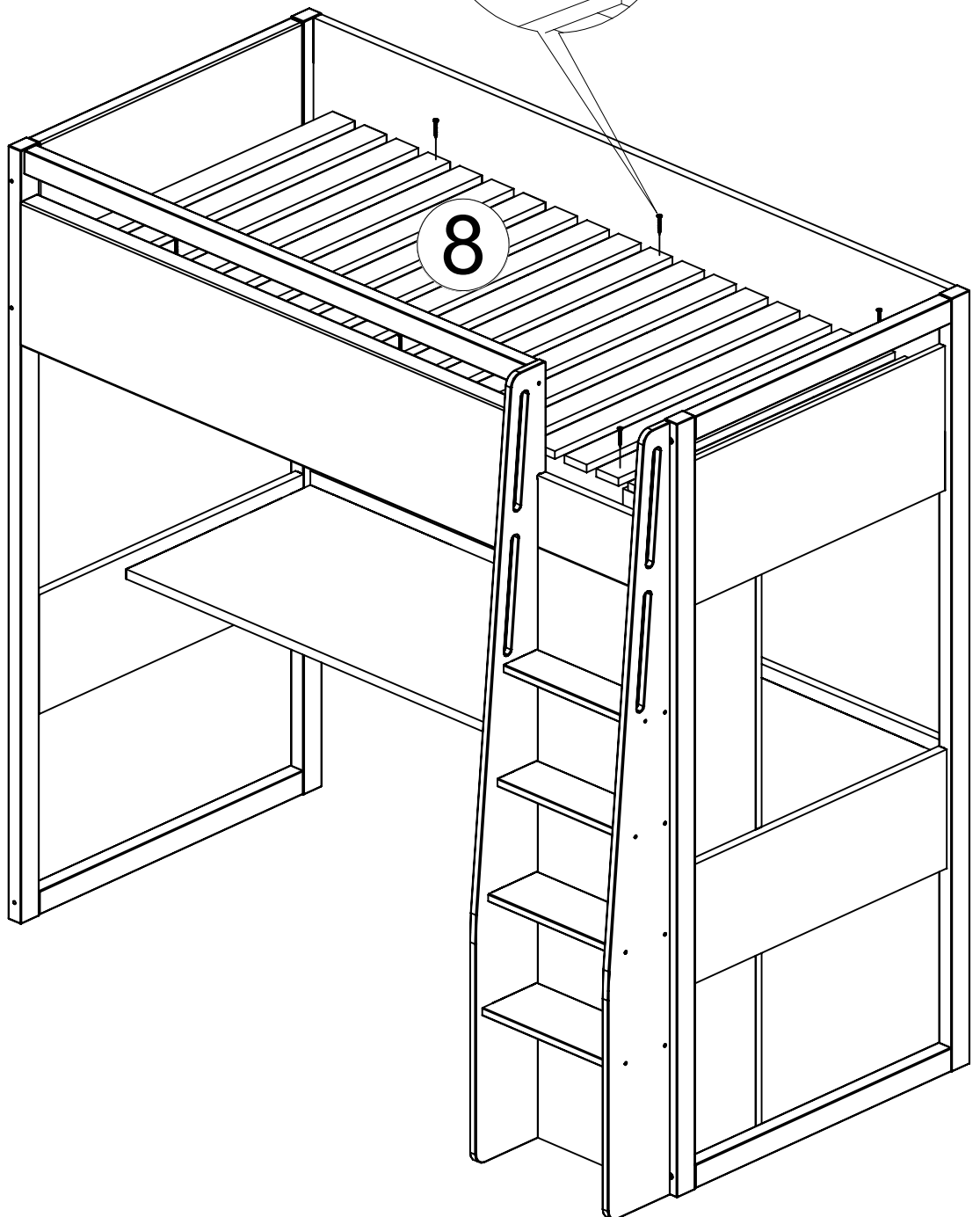

IMPORTANT- PASTRATI INSTRUCȚIUNILE PENTRU UTILIZARE ULTERIOARA. CITIȚI CU ATENȚIE ACESTE INSTRUCȚIUNI ÎNAINTE DE ASAMBLARE
MANUALUL UTILIZATORULUI

1. Asamblarea trebuie efectuată în conformitate cu instrucțiunile producătorului - din schita de montaj - în caz contrar, siguranța poate fi pusă în pericol.
2. Pentru a evita pericolul de sufocare, nu lăsați ambalajul de plastic la îndemâna bebelușilor și a copiilor.
3. Toate conexiunile trebuie să fie strânse corect și nu trebuie lăsate libere.
4. Atenție: Fiți conștienți de riscul unor surse puternice de căldură, cum ar fi radiatoarele etc., care pot fi situate în apropierea sertarului de pat sau a altor piese de mobilier, deoarece acest lucru le-ar putea cauza deteriorări majore.
5. Atenție: Nu utilizați sertarul de pat dacă oricare dintre secțiuni este deteriorată sau în cazul în care există elemente care lipsesc. Utilizați numai acele elemente care sunt furnizate de către producător.
6. Toate elementele trebuie să fie păstrate curate.

WICHTIGE HINWEISE, FÜR DIE SPÄTERE NUTZUNG AUFBEWAHREN- GENAU LESEN
BEDIENUNGSANWEISUNG

1. Die Montage sollte in Übereinstimmung mit den Anweisungen des Herstellers erfolgen - andernfalls kann ein Sicherheitsrisiko entstehen.
2. Die Kunststoffverpackung an einem für die Kinder nicht zugänglichen Ort halten, um das Risiko des Erstickens zu vermeiden.
3. Alle Verbindungen müssen richtig hergestellt werden, kein Verbindungsteil darf lose sein.
4. Warnung: Seien Sie sich des Risikos, das ein offenes Feuer sowie andere Wärmequellen wie elektrische Wärme- oder Gasstrahler usw., gestellt in der Nähe des Bettes, darstellen, bewusst.
5. Warnung: das Bett nicht benutzen, wenn ein Teil beschädigt, gerissen ist oder fehlt, nur die vom Hersteller zugelassenen Teile verwenden.
6. Alle Teile sind sauber zu halten.

Zachować do późniejszego stosowania.

Uważnie przeczytać.

Keep for later use.

Read carefully.

Сохраните для последующего использования.

Прочитай внимательно.

Păstrați pentru utilizare ulterioară.

Citește cu atenție.

Säilytä myöhempää käyttöä varten.

Lue huolellisesti.

Maksymalna wysokość górnej płaszczyzny materaca.

Maximum height of the top surface of the mattress.

Максимальная высота верхней поверхности матраса.

Înălțimea maximă a suprafeței superioare a saltelei.

Maximale Höhe der Oberseite der Matratze.

Patjan yläpinnan enimmäiskorkeus.

Zalecana grubość materaca wynosi 160 mm.

The recommended mattress thickness is 160 mm.

Рекомендуемая толщина матраса 160 мм.

Grosimea recomandată a saltelei este de 160 mm.

Die empfohlene Matratzenstärke beträgt 160 mm.

Suositteltu patjan paksuus on 160 mm.

